

THE HARDWARE SHOWN IS THE ONLY HARDWARE PROVIDED WHEN ORDERING A ERIC MORRIS 2700 LOCKING OR PRIVACY CREMONE.

ALL ADDITIONAL HARDWARE MUST BE SPECIFIED AND ORDERED SEPERATELY.

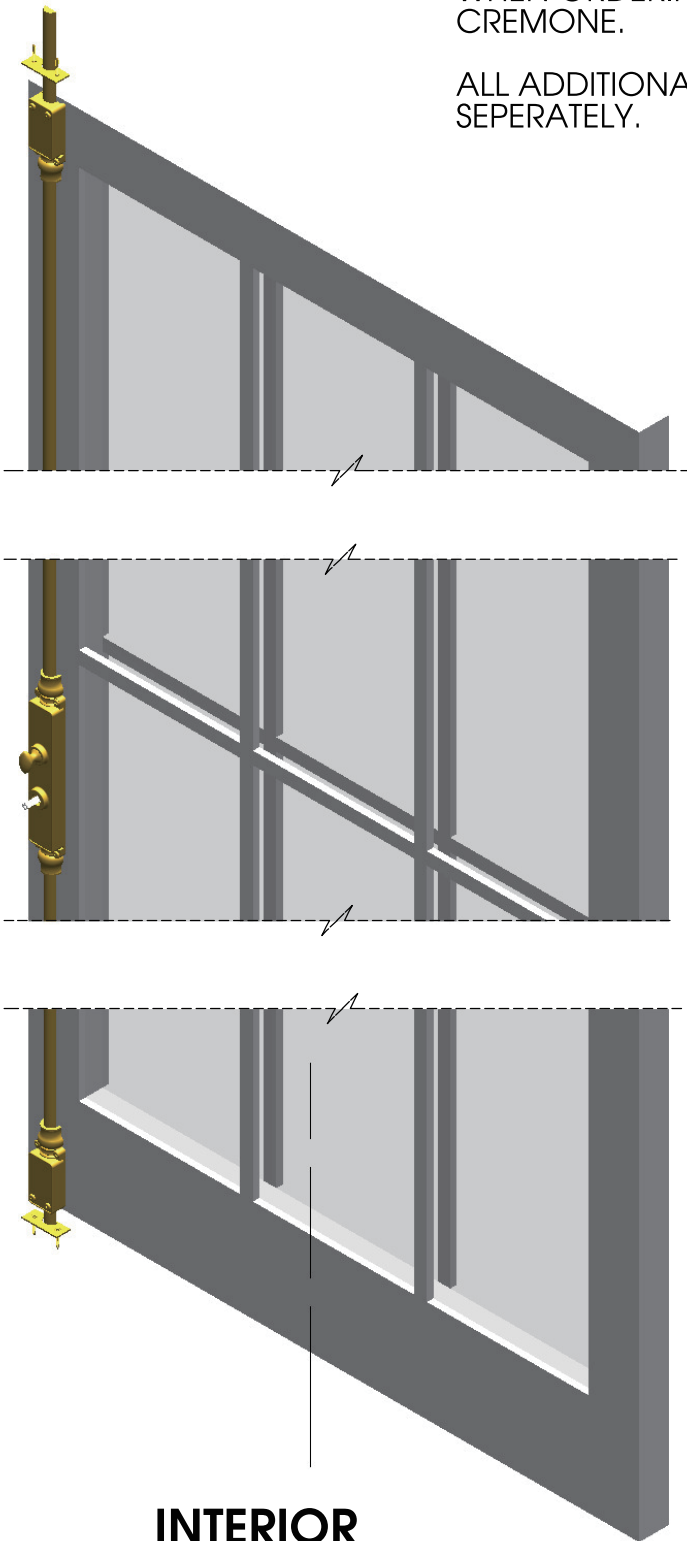

**INTERIOR**

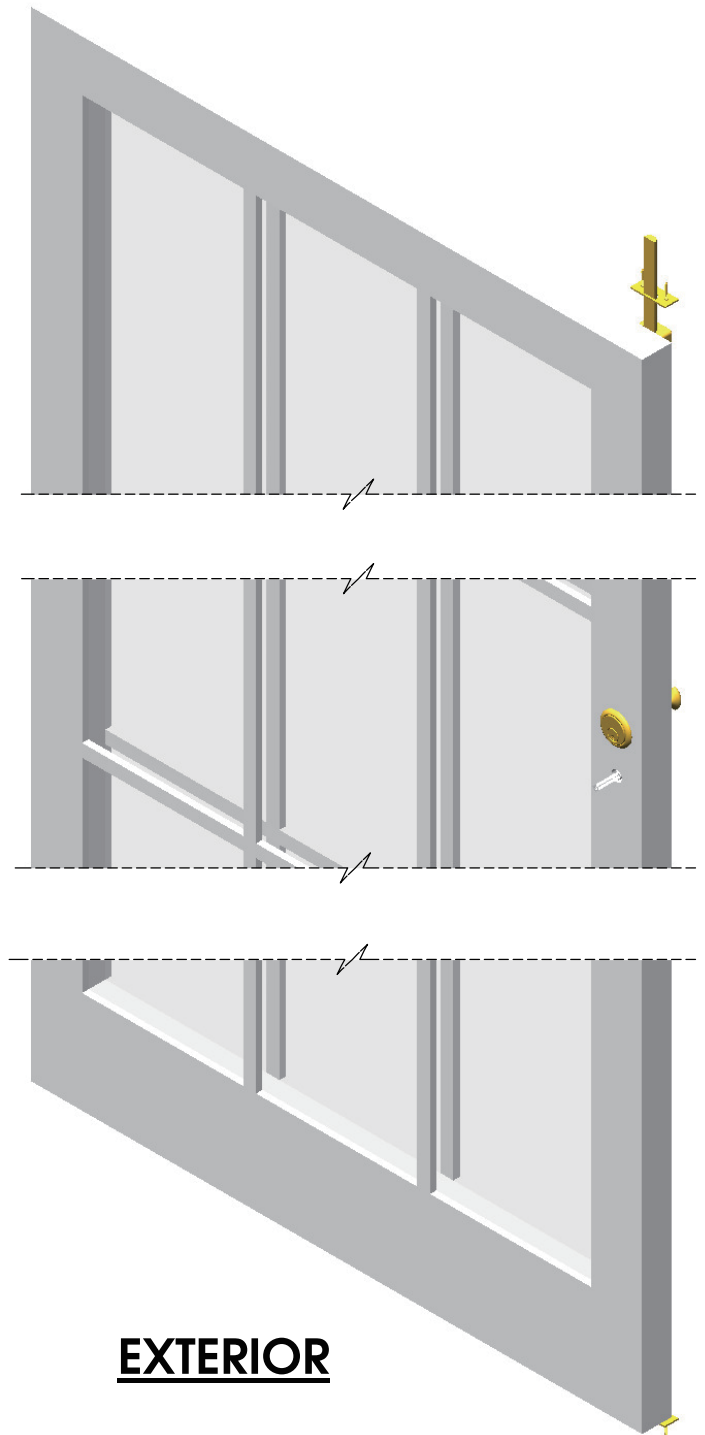

**EXTERIOR**

THE INFORMATION CONTAINED IN THIS DRAWING IS THE SOLE PROPERTY OF ERIC MORRIS & COMPANY. ANY REPRODUCTION IN PART OR AS A WHOLE WITHOUT THE WRITTEN PERMISSION OF ERIC MORRIS & COMPANY IS STRICTLY PROHIBITED.

TITLE:

DO NOT SCALE DRAWING

SCALE:1:1

SHEET 1 OF 1



Phone: +1-856-997-0222  
 Fax: +1-856-294-5116  
 Email: [info@ericmorrisandco.com](mailto:info@ericmorrisandco.com)  
 Web: <http://www.ericmorrisandco.com>  
 Address: ERIC MORRIS & COMPANY  
 7249-A Browning Road  
 Pennsauken, NJ 08109

# DOOR PREPARATION GUIDE FOR 2700 LOCKING CREMONE

*for all visual references, please refer to sheets 2 and 3 of the door preparation guide*

- 1) Begin by laying door flat across workbenches or saw horses. Mark a short horizontal line from bottom of door the determined spindle height (standard is 42"). Now mark a vertical line at a designated distance in from edge of the door extending 5" above and below this line (standard inset is 1/2 the width of the mounting surface, i.e. from edge to glass). This cross-point will be the center point for the spindle and reference point (A) for the remaining cremone bolt layout.
- 2) If using the rim cylinder measure **2 7/16" (62mm)** up along the vertical line and mark a point (B) for the rim cylinder. Using a 7/64" drill bit, drill a pilot hole through the door and then using the 1 1/4" bit, bore a hole halfway through both sides of the door.
- 3) Place the rim cylinder retainer plate over the bored hole with the three holes in the center of the plate oriented towards point (A) and lightly mark the outline of the plate. Carefully mortise a recess for the retainer plate so when installed it will sit just below flush with the surface of the door (approximately 1/16" deep). It may be helpful to outline the cremone case to be sure to avoid extending the mortise too far on either side.
- 4) Measure **4 29/32" (113.25m)** above and **2 27/32" (72.2mm)** below point (A) and mark short horizontal lines. Mark points along these horizontal lines 9/16" on either side of the vertical center lines, points (C). Using a 7/64" bit drill a hole 3/4" deep at each of these four points. These will be the mounting points for the cremone operator body.
- 5) Measure down from point (A) 21 1/2" and mark the location of the top hole of the concealed mounting guide, point (D). Be sure it is vertically aligned with point (A). Place the concealed guide with the top hole centered on point (D) and mark the bottom hole, point (E).
- 6) For 7' (84") and 8' (96") doors, measure 23 1/2" up from point (A) and mark the bottom hole of the top concealed guide, point (F) ensuring that once again this point is vertically aligned with point (A). Place the concealed guide with the bottom hole centered over point (F) and mark the top hole, point (G). NOTE: For 9' (108") or 10' (120") the above measurement needs to be increased to **46 15/16"** from 23 1/2".
- 7) Use a straight edge to confirm points (C) thru (G) are properly aligned with point (A). Improper alignment will result in increased stress on the components and potential failure of the mechanism. Using a **3/32"** bit drill holes at points (D), (E), (F) and (G).
- 8) Use a chisel or router to mortise a 1 3/4" (l) x 3/8" (w) x 3/16" (d) groove between points (D) and (E) and a second one between (F) and (G). Allow approximately 3/16" clearance between the screw holes and each end of the slot.
- 9) Clean out the slots and install top and bottom concealed guides using the #6 flat head wood screws provided. Be sure the concealed guides are installed so that the large hole is oriented towards the cremone housing on both the top and bottom.
- 10) For end guide placement begin by making a vertical centerline at each end of the door that is vertically aligned with point (A). Verify that once the end guide is installed it will not interfere with the door closing properly. From the top and bottom of the door (or point of clearance), measure in 3" and mark a short line perpendicular to the vertical centerline. Mark two points along this horizontal line 9/16" on either side of the vertical line. From each of the horizontal lines measure out toward the edge of the door 2 1/2" and mark a second horizontal line. Now mark a point 7/16" on either side of the vertical centerline. These will be points (H) and (I).
- 11) Using a **7/64"** bit drill a hole 3/4" deep at each of the four points (H) and (I). Be sure to remove any marking lines that would extend beyond the outline of the end guides. Place the end guide centered over the screw holes and lightly mark the outside edge (closest to edge of the door) of the guide. Do not install the end guides at this time.
- 12) Bore a hole using a 5/8" bit at point (A). For one sided applications bore the hole only 1/4" deep to provide clearance for the spindle. For double sided applications bore the hole through the door (it is recommended to drill a pilot hole first and to drill the main bore from both sides of the door to avoid splitting or otherwise damaging the door).

THE INFORMATION CONTAINED IN THIS DRAWING IS THE SOLE PROPERTY OF ERIC MORRIS & COMPANY. ANY REPRODUCTION IN PART OR AS A WHOLE WITHOUT THE WRITTEN PERMISSION OF ERIC MORRIS & COMPANY IS STRICTLY PROHIBITED.

TITLE:

DO NOT SCALE DRAWING

SCALE:1:1

SHEET 1 OF 1



Phone: +1-856-997-0222  
Fax: +1-856-294-5116  
Email: [info@ericmorrisandco.com](mailto:info@ericmorrisandco.com)  
Web: <http://www.ericmorrisandco.com>  
Address: ERIC MORRIS & COMPANY  
7249-A Browning Road  
Pennsauken, NJ 08109

# DOOR PREPARATION GUIDE FOR 2700 LOCKING CREMONE (pg 2)

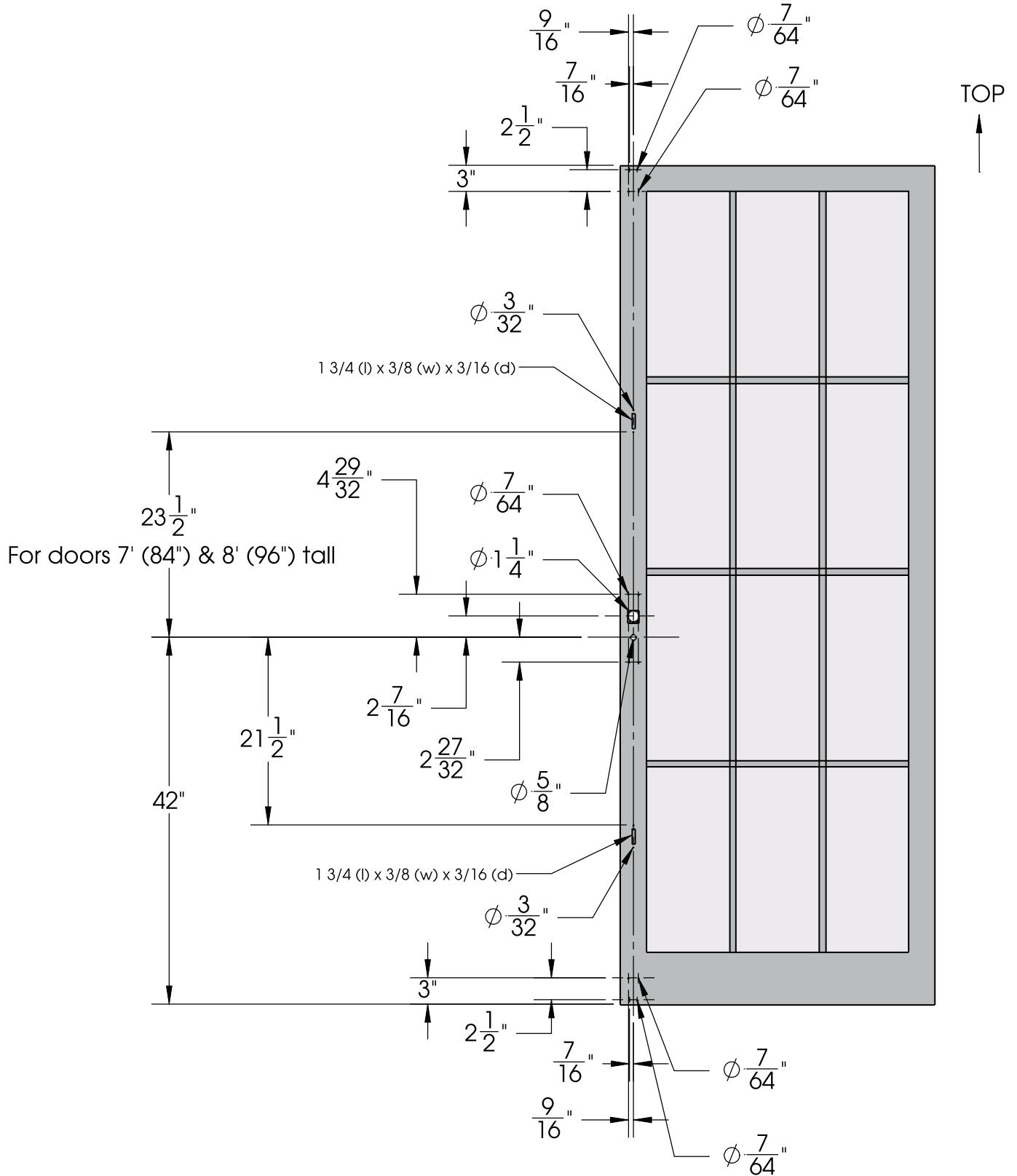

THE INFORMATION CONTAINED IN THIS DRAWING IS THE SOLE PROPERTY OF ERIC MORRIS & COMPANY. ANY REPRODUCTION IN PART OR AS A WHOLE WITHOUT THE WRITTEN PERMISSION OF ERIC MORRIS & COMPANY IS STRICTLY PROHIBITED.

TITLE:

DO NOT SCALE DRAWING

SCALE:1:1

SHEET 1 OF 1



Phone: +1-856-997-0222  
 Fax: +1-856-294-5116  
 Email: [info@ericmorrisandco.com](mailto:info@ericmorrisandco.com)  
 Web: <http://www.ericmorrisandco.com>  
 Address: ERIC MORRIS & COMPANY  
 7249-A Browning Road  
 Pennsauken, NJ 08109

# DOOR PREPARATION GUIDE FOR 2700 LOCKING CREMONE (pg 3)

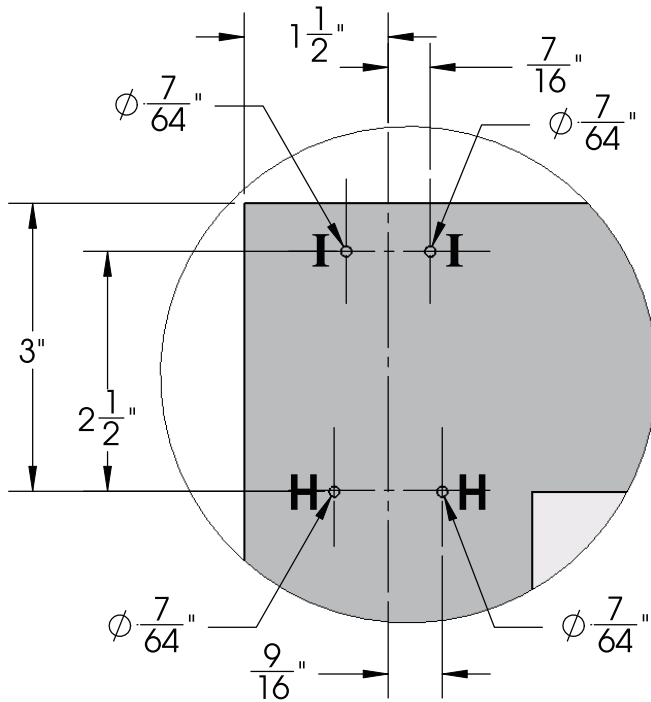

DETAIL D  
(Upper End Guide Detail)  
SCALE 1 : 2

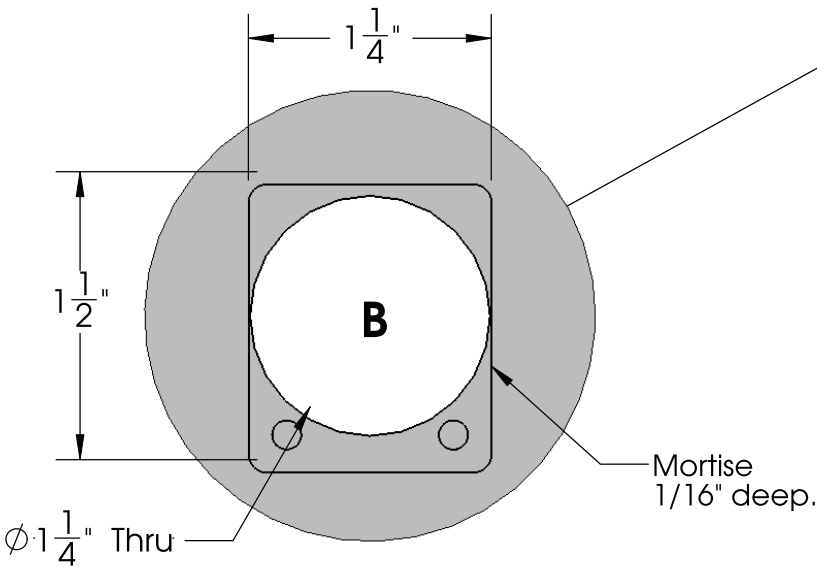

DETAIL B  
(Retainer Plate Mortise Detail)  
SCALE 1 : 1

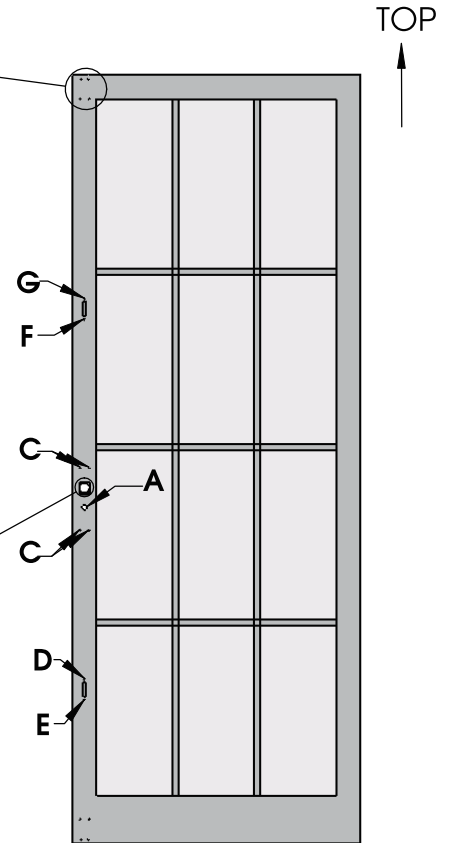

THE INFORMATION CONTAINED IN THIS DRAWING IS THE SOLE PROPERTY OF ERIC MORRIS & COMPANY. ANY REPRODUCTION IN PART OR AS A WHOLE WITHOUT THE WRITTEN PERMISSION OF ERIC MORRIS & COMPANY IS STRICTLY PROHIBITED.

TITLE:

DO NOT SCALE DRAWING

SCALE:1:1

SHEET 1 OF 1



Phone: +1-856-997-0222  
 Fax: +1-856-294-5116  
 Email: [info@ericmorrisandco.com](mailto:info@ericmorrisandco.com)  
 Web: <http://www.ericmorrisandco.com>  
 Address: ERIC MORRIS & COMPANY  
 7249-A Browning Road  
 Pennsauken, NJ 08109

ITEM NO.	PART NUMBER	Default/ QTY.	NOTES
1	French Door - 2701	1	
2	Concealed Guide	2	
3	Cremone Housing & Cassette	1	
6	Retainer Plate	1	
7	Cylinder Collar	1	
8	Rim Cylinder	1	
9	CR-PHMS 0.19-24x1.875x1.875-S	2	
10	Lower Shoot Bolt	1	
11	Shoulder Screw	2	
12	Upper Shoot Bolt	1	
13	PANHTS 0.164-19-type I-AB-1.25-S	12	
14	Cremone End Guide	2	
15	Cremone Frog	4	
16	Oval Knob	2	1
17	Cremone Mortise Strike	2	
18	FLATCKT 0.138-20-type IA-AB-1-S	4	
19	Thumb Turn	1	2
23	8850 - Traditional Rose	1	1
25	CR-FHMS 0.19-24x0.25x0.25-S	2	

Notes:

Product listing above is for a typical locking cremone bolt application. Certain restrictions apply, see notes below.

1 - All trim (knobs, rosettes, etc) are supplied separately and at additional cost to the 2700 Cremone System.

2 - Traditional thumb turn supplied as standard. Suited thumb turns available at additional cost and *any changes MUST BE specified at the time of ordering.*

3 - Traditional frogs supplied as standard. Suited frogs available at additional cost and *any changes MUST BE specified at the time of ordering.*



THE INFORMATION CONTAINED IN THIS DRAWING IS THE SOLE PROPERTY OF ERIC MORRIS & COMPANY. ANY REPRODUCTION IN PART OR AS A WHOLE WITHOUT THE WRITTEN PERMISSION OF ERIC MORRIS & COMPANY IS STRICTLY PROHIBITED.

TITLE:

DO NOT SCALE DRAWING

SCALE:1:1

SHEET 1 OF 1



Phone: +1-856-997-0222  
 Fax: +1-856-294-5116  
 Email: [info@ericmorrisandco.com](mailto:info@ericmorrisandco.com)  
 Web: <http://www.ericmorrisandco.com>  
 Address: ERIC MORRIS & COMPANY  
 7249-A Browning Road  
 Pennsauken, NJ 08109

# CREMONE SET-UP AND HANDING

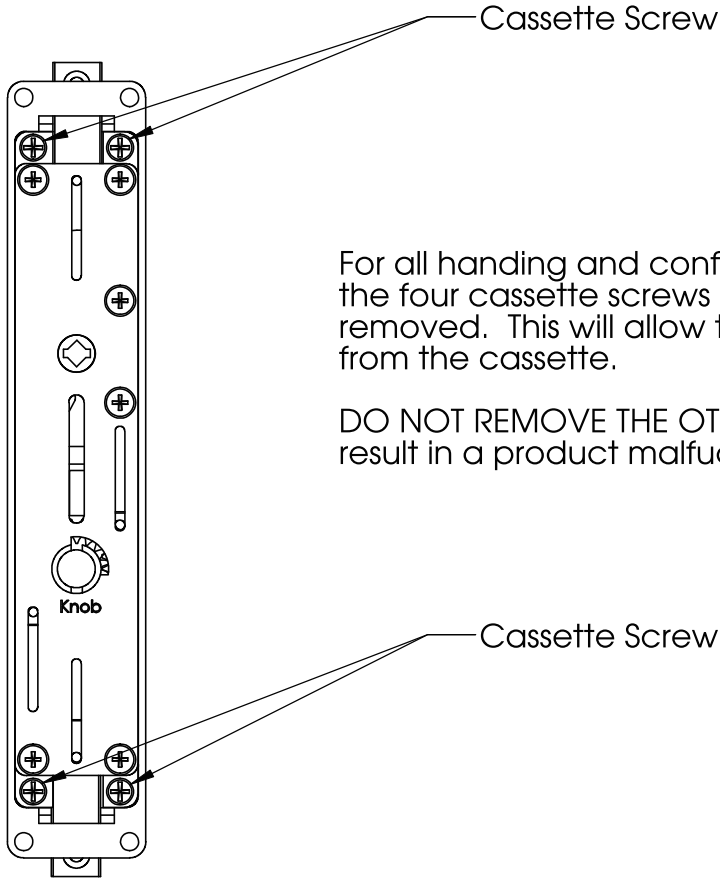

For all handing and configuration changes, only the four cassette screws indicated should be removed. This will allow the cremone housing to separate from the cassette.

DO NOT REMOVE THE OTHER SIX SCREWS as this could result in a product malfunction.

Cassette Screw

THE INFORMATION CONTAINED IN THIS DRAWING IS THE SOLE PROPERTY OF ERIC MORRIS & COMPANY. ANY REPRODUCTION IN PART OR AS A WHOLE WITHOUT THE WRITTEN PERMISSION OF ERIC MORRIS & COMPANY IS STRICTLY PROHIBITED.

TITLE:

DO NOT SCALE DRAWING

SCALE:1:1

SHEET 1 OF 1



Phone: +1-856-997-0222  
Fax: +1-856-294-5116  
Email: [info@ericmorrisandco.com](mailto:info@ericmorrisandco.com)  
Web: <http://www.ericmorrisandco.com>  
Address: ERIC MORRIS & COMPANY  
7249-A Browning Road  
Pennsauken, NJ 08109

# CREMONE SET-UP AND HANDING

## LEFT HAND OR RIGHT HAND REVERSE BEVEL KNOB OPERATION

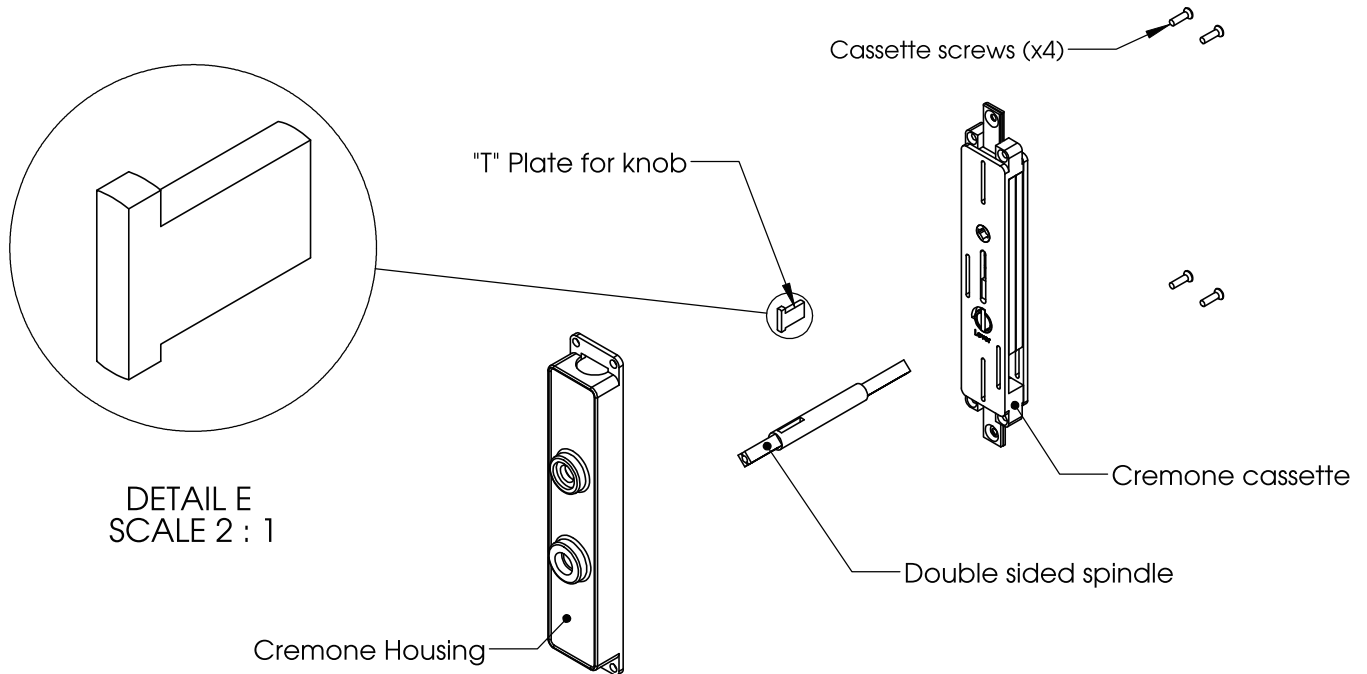

- 1) Remove the cassette by removing the four (4) cassette screws per page 1 of the cremone set-up and handing guide.
- 2) Locate the knob "T" plate, shown above and in Detail E (the plate may be scribed with a K but can be distinguished by equal length tabs).
- 3) Slide the "T" plate into the spindle exactly as shown above with the tabs closest to the square portion of the spindle.
- 4) Slide the spindle and "T" plate sub assembly into the cassette from the side marked Lever (the knob side should be exposed at the back after installation). Ensure that the tabs protruding from the spindle engage the slot in the spindle cut-out of the cassette (see detail F below).
- 5) Place cremone housing back over top of the cassette and replace the four (4) cassette screws to complete the assembly.

NOTE 1: The cremone will *lock* when the knob is turned to the left. The knob will rotate 180 degrees.

NOTE 2: To reverse the handing of the knob function, remove the cassette, flip it 180 degrees (this will ensure that the word lever is showing on the back of the cassette), install the spindle and "T" plate per step 4 and replace the cassette screws as per step 5.

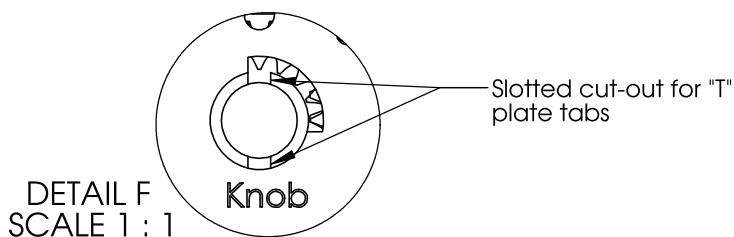

THE INFORMATION CONTAINED IN THIS DRAWING IS THE SOLE PROPERTY OF ERIC MORRIS & COMPANY. ANY REPRODUCTION IN PART OR AS A WHOLE WITHOUT THE WRITTEN PERMISSION OF ERIC MORRIS & COMPANY IS STRICTLY PROHIBITED.

TITLE:

DO NOT SCALE DRAWING

SCALE:1:1

SHEET 1 OF 1



Phone: +1-856-997-0222  
Fax: +1-856-294-5116  
Email: [info@ericmorrisandco.com](mailto:info@ericmorrisandco.com)  
Web: <http://www.ericmorrisandco.com>  
Address: ERIC MORRIS & COMPANY  
7249-A Browning Road  
Pennsauken, NJ 08109

# CREMONE SET-UP AND HANDING

## LEFT HAND OR RIGHT HAND REVERSE BEVEL LEVER OPERATION

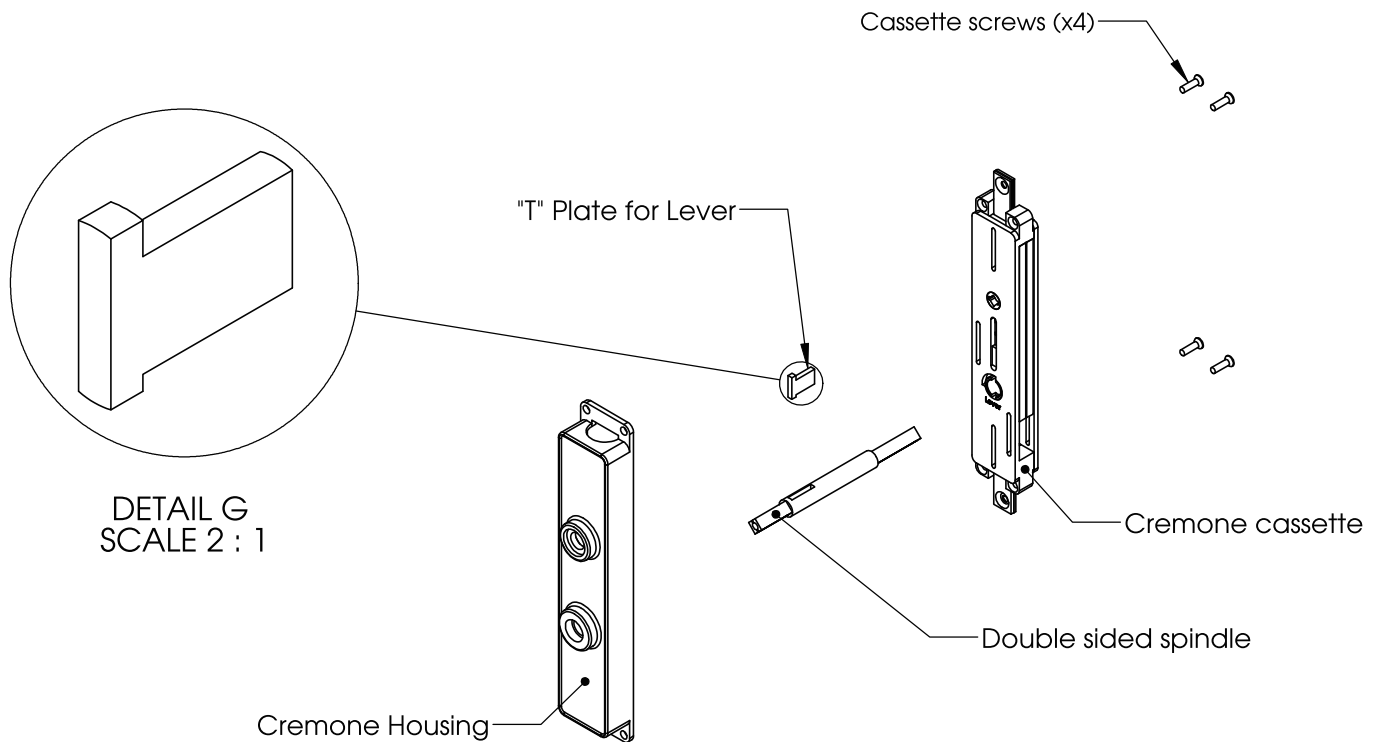

1) Remove the cassette by removing the four (4) cassette screws per page 1 of the cremone set-up and handing guide.

2) Locate the lever "T" plate, shown above and in Detail G (the plate may be scribed with an L but can be distinguished by the fact that one tab is longer than the other).

3) Slide the "T" plate into the spindle exactly as shown above with the tabs closest to the square portion of the spindle.

4) Slide the spindle and "T" plate sub assembly into the cassette from the side marked lever (the knob side should be exposed at the back after installation). Ensure that the tabs protruding from the spindle engage the slot in the spindle cut-out of the cassette and that the long tab falls into the arced recess in the cassette (see detail H below).

5) Place cremone housing back over top of the cassette and replace the four (4) cassette screws to complete the assembly.

NOTE: The lever will be at the 9 o'clock position when locked (when facing the door it will be pointing to the left). When unlocked, the lever should be at the 12 o'clock position. This is the *proper* function of a cremone lever and it is limited to 90 degrees of rotation.

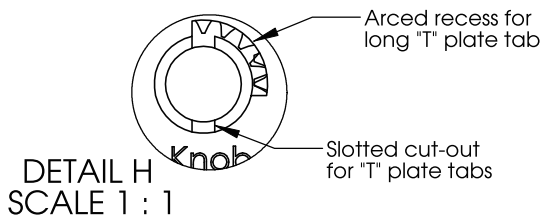

THE INFORMATION CONTAINED IN THIS DRAWING IS THE SOLE PROPERTY OF ERIC MORRIS & COMPANY. ANY REPRODUCTION IN PART OR AS A WHOLE WITHOUT THE WRITTEN PERMISSION OF ERIC MORRIS & COMPANY IS STRICTLY PROHIBITED.

TITLE:

DO NOT SCALE DRAWING

SCALE:1:1

SHEET 1 OF 1



Phone: +1-856-997-0222  
 Fax: +1-856-294-5116  
 Email: [info@ericmorrisandco.com](mailto:info@ericmorrisandco.com)  
 Web: <http://www.ericmorrisandco.com>  
 Address: ERIC MORRIS & COMPANY  
 7249-A Browning Road  
 Pennsauken, NJ 08109



# CREMONE SET-UP AND HANDING

## RIGHT HAND OR LEFT HAND REVERSE BEVEL LEVER OPERATION

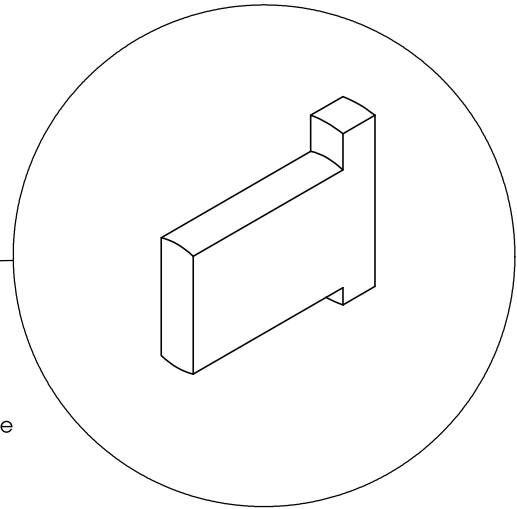
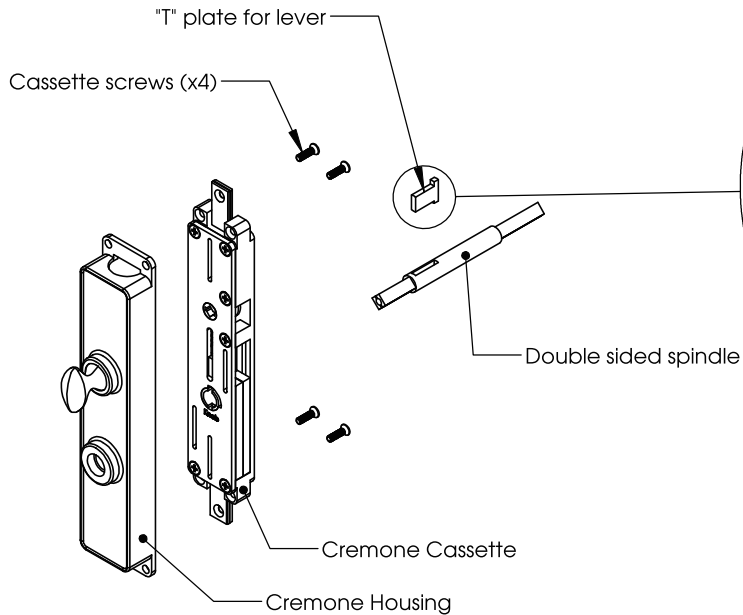

DETAIL AA  
SCALE 2 : 1

- 1) Remove the cassette by removing the four (4) cassette screws per page 1 of the cremone set-up and handing guide.
- 2) Locate the lever "T" plate, shown above and in Detail AA (the plate may be scribed with an L but can be distinguished by the fact that one tab is longer than the other).
- 3) Slide the "T" plate into the spindle exactly as shown above with the tabs away from the square portion of the spindle.
- 4) Slide the spindle and "T" plate sub assembly into the cassette from the side marked lever (the lever side should be exposed at the back after installation). Ensure that the tabs protruding from the spindle engage the slot in the spindle cut-out of the cassette and that the long tab falls into the arced recess in the cassette (see detail AB below).
- 5) Place cremone housing back over top of the cassette and replace the four (4) cassette screws to complete the assembly.

NOTE: The lever will be at the 3 o'clock position when locked (when facing the door it will be pointing to the right). When unlocked, the lever should be at the 12 o'clock position. This is the *proper* function of a cremone lever.

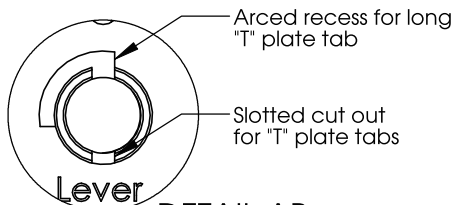

DETAIL AB  
SCALE 1 : 1

THE INFORMATION CONTAINED IN THIS DRAWING IS THE SOLE PROPERTY OF ERIC MORRIS & COMPANY. ANY REPRODUCTION IN PART OR AS A WHOLE WITHOUT THE WRITTEN PERMISSION OF ERIC MORRIS & COMPANY IS STRICTLY PROHIBITED.

TITLE:

DO NOT SCALE DRAWING

SCALE:1:1

SHEET 1 OF 1



Phone: +1-856-997-0222  
 Fax: +1-856-294-5116  
 Email: [info@ericmorrisandco.com](mailto:info@ericmorrisandco.com)  
 Web: <http://www.ericmorrisandco.com>  
 Address: ERIC MORRIS & COMPANY  
 7249-A Browning Road  
 Pennsauken, NJ 08109

# LOCKING CREMONE BOLT INSTALLATION INSTRUCTIONS

- 1) Place cylinder collar over the rim cylinder and push the cylinder into the bored hole at point A from outside of the door (keyway should be oriented toward the bottom of the door).
- 2) Mark the spindle at 3/8" projection from the face of the retainer plate. Remove the cylinder and cut the spindle at the marked point.
- 3) The cylinder screws may also need to be cut. They should be 1/2" short of the outside surface of the door.

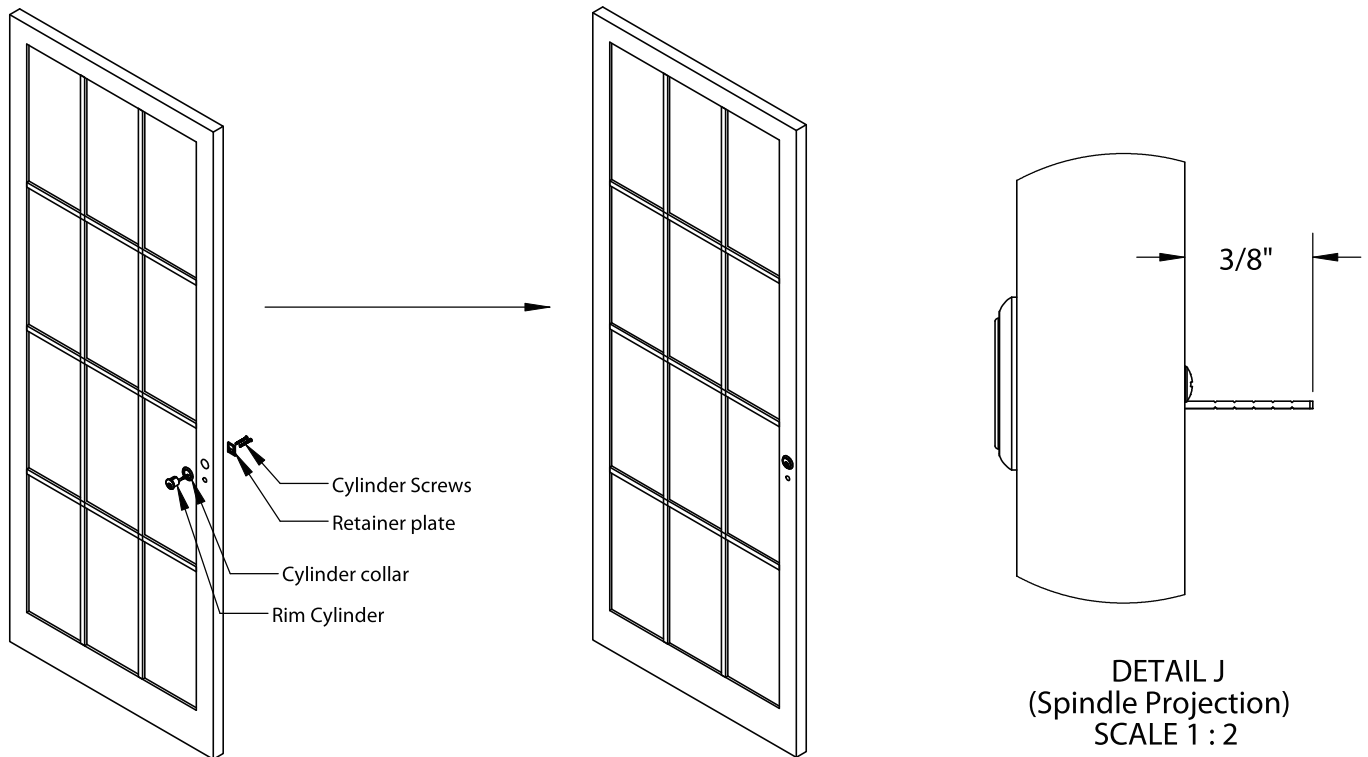

- 4) Place the cylinder back into the bored hole from the outside of the door. Support the cylinder with one hand and install the retainer plate into the mortise at the inside face of the door. Install the two screws through the retainer plate and into the cylinder, making sure to tighten the screws until snug.
- 5) Rotate the flat spindle (cylinder tailpiece) clockwise until it stops to ensure proper orientation and locking function.

THE INFORMATION CONTAINED IN THIS DRAWING IS THE SOLE PROPERTY OF ERIC MORRIS & COMPANY. ANY REPRODUCTION IN PART OR AS A WHOLE WITHOUT THE WRITTEN PERMISSION OF ERIC MORRIS & COMPANY IS STRICTLY PROHIBITED.

TITLE:

DO NOT SCALE DRAWING

SCALE:1:1

SHEET 1 OF 1



Phone: +1-856-997-0222  
Fax: +1-856-294-5116  
Email: [info@ericmorrisandco.com](mailto:info@ericmorrisandco.com)  
Web: <http://www.ericmorrisandco.com>  
Address: ERIC MORRIS & COMPANY  
7249-A Browning Road  
Pennsauken, NJ 08109

6) With cremone body and spindle configured for proper handing and trim, attach the knob or lever (depending on desired application) over the spindle and tighten the set screws on the knob or lever.

7) Rotate the knob or lever to the locked position in order to expose the bolt attachment rod as shown, below right and in Detail AC. Place the operator body onto the door in the proper position.

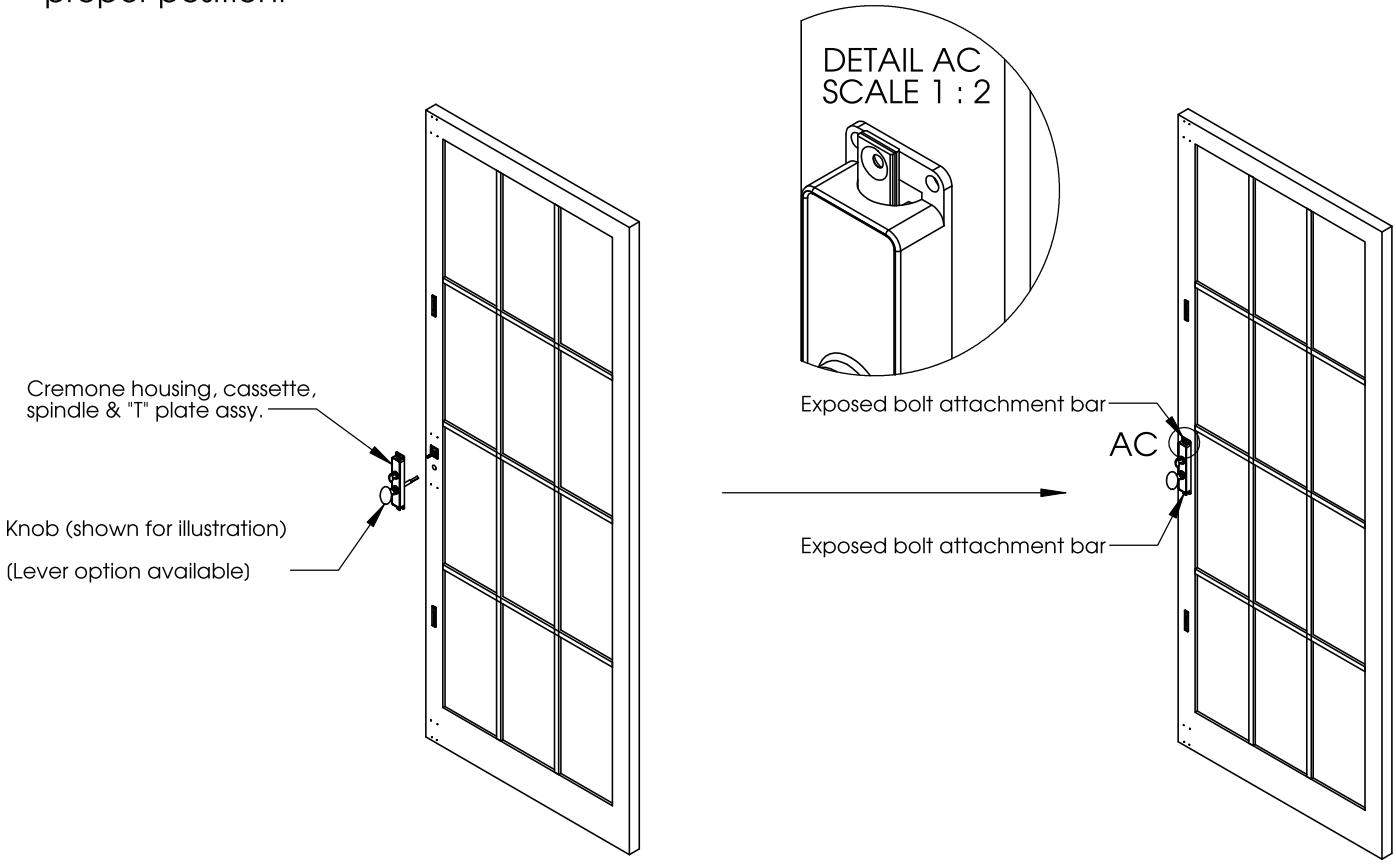

8) Apply a drop of Loctite to the shoulder screw as shown below in Detail K. Install the shoulder screw into both the top and bottom shoot bolts.

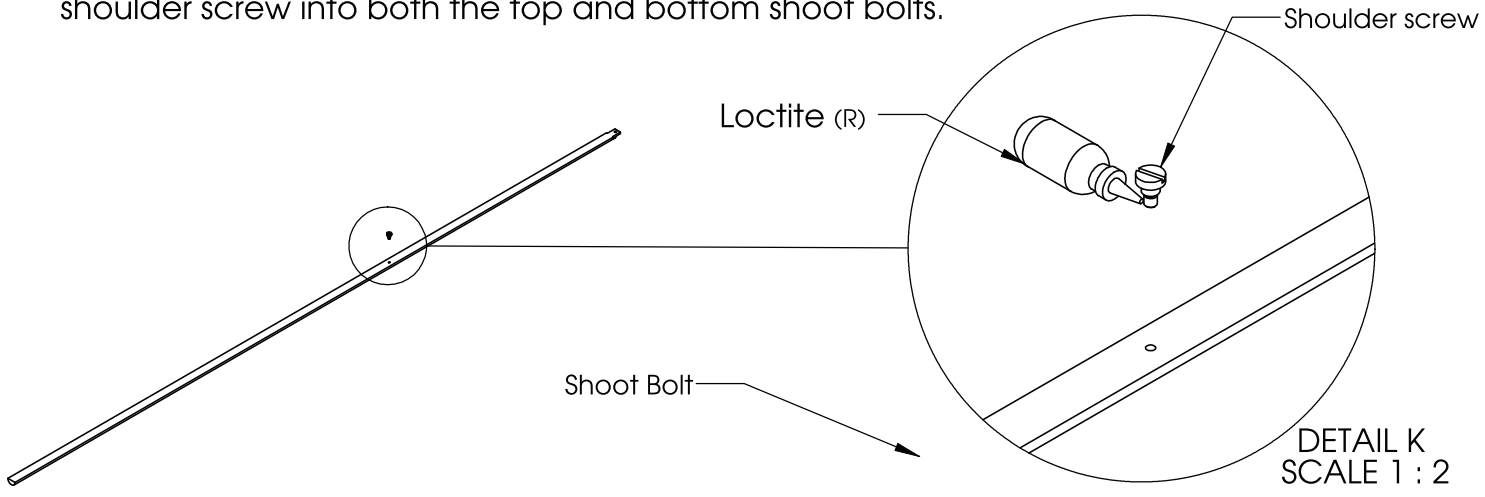

THE INFORMATION CONTAINED IN THIS DRAWING IS THE SOLE PROPERTY OF ERIC MORRIS & COMPANY. ANY REPRODUCTION IN PART OR AS A WHOLE WITHOUT THE WRITTEN PERMISSION OF ERIC MORRIS & COMPANY IS STRICTLY PROHIBITED.

TITLE:

**DO NOT SCALE DRAWING**

SCALE:1:1 SHEET 1 OF 1



Phone: +1-856-997-0222  
 Fax: +1-856-294-5116  
 Email: [info@ericmorrisandco.com](mailto:info@ericmorrisandco.com)  
 Web: <http://www.ericmorrisandco.com>  
 Address: ERIC MORRIS & COMPANY  
 7249-A Browning Road  
 Pennsauken, NJ 08109

9) Place the upper and lower shoot bolts onto the door ensuring that the shoulder screws engage the upper portion of the keyed slot on the concealed guides\* (shown in the detail, N, below).

10) Slide the shoulder screw down the keyed slot to prevent removal before pivoting the bars into position to attach the # 10 x 1/4" machine screws as shown to the right.

\*Concealed guides should have been installed during the door prep phase after the slots were mortised out to allow clearance for the shoulder screw. See door prep guide for details.

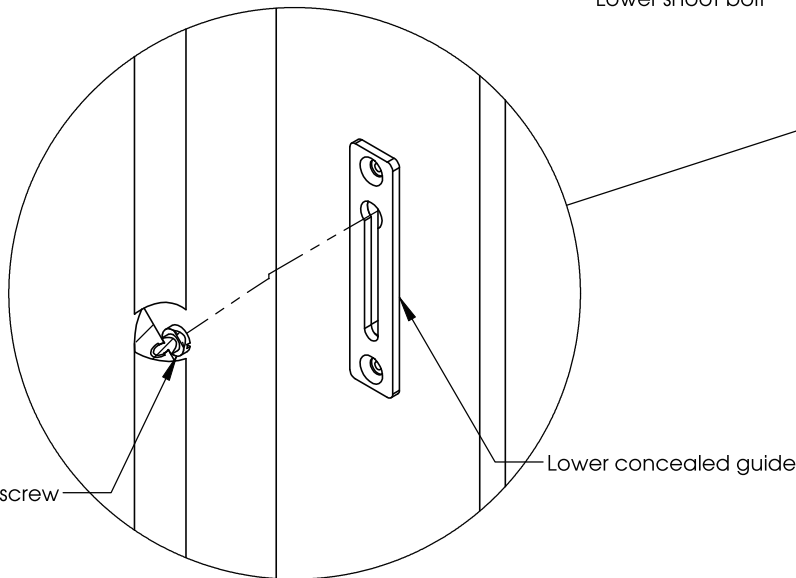
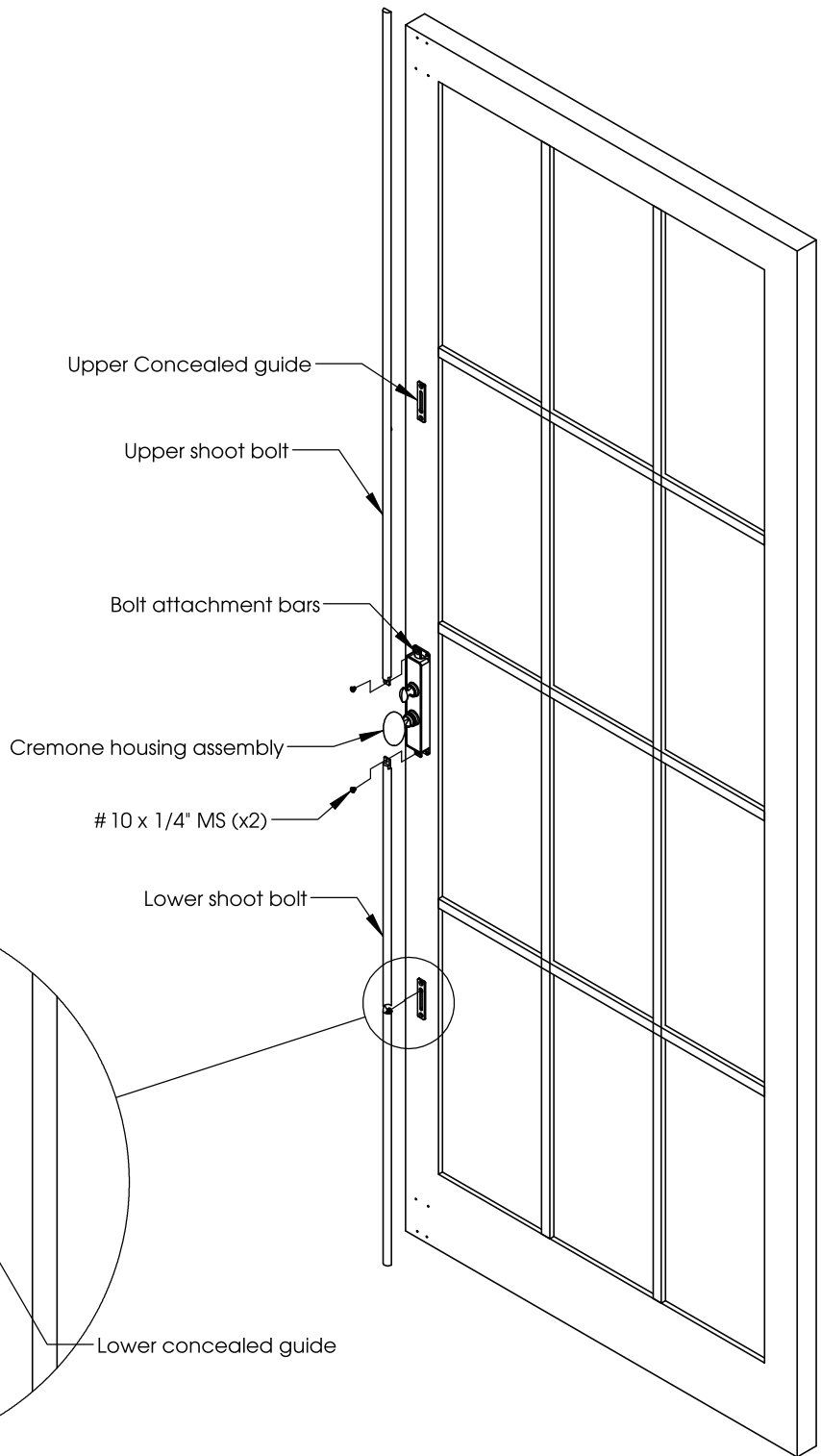

DETAIL N  
SCALE 1 : 2

THE INFORMATION CONTAINED IN THIS DRAWING IS THE SOLE PROPERTY OF ERIC MORRIS & COMPANY. ANY REPRODUCTION IN PART OR AS A WHOLE WITHOUT THE WRITTEN PERMISSION OF ERIC MORRIS & COMPANY IS STRICTLY PROHIBITED.

TITLE:

DO NOT SCALE DRAWING

SCALE:1:1

SHEET 1 OF 1



Phone: +1-856-997-0222  
 Fax: +1-856-294-5116  
 Email: [info@ericmorrisandco.com](mailto:info@ericmorrisandco.com)  
 Web: <http://www.ericmorrisandco.com>  
 Address: ERIC MORRIS & COMPANY  
 7249-A Browning Road  
 Pennsauken, NJ 08109

11) Loosely attach the cremone case to the door using the four (4) # 8 x 1" Phillips Round head wood screws as shown at right (do not tighten the screws all the way down at this time).

12) Rotate the knob or lever to the unlocked position to fully retract the shoot bolts. Mark the top shoot bolt just inside line (1) and the bottom shoot bolt just inside line (2).

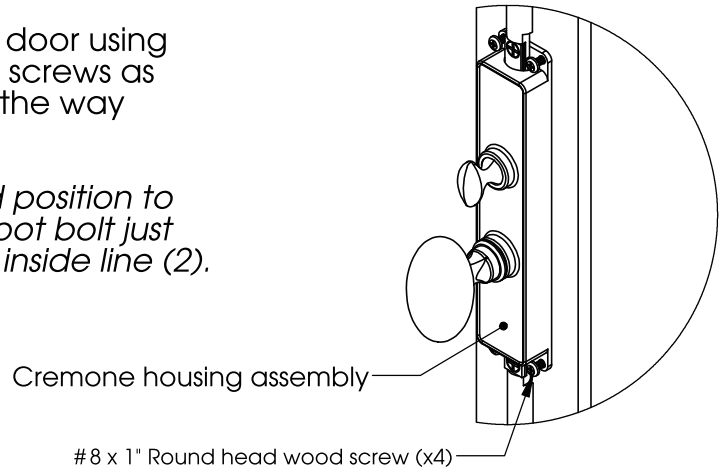

13) Re-extend the shoot bolts by turning the lever or knob back to the locked position and remove the # 10 machine screws. Carefully slide and then swing the shoot bolts in order to remove them from the concealed guides. Using a hacksaw or reciprocating saw, cut the shoot bolts to the proper length and remove any sharp edges and flashing with a file.

14) With shoot bolts cut to length, carefully slide an end guide over the end of each bolt as shown below, ensuring that the flange is oriented towards the cremone case. To avoid scratching the bolt, slide the guide so the end of the bolt is slightly protruding through the outside of the guide.

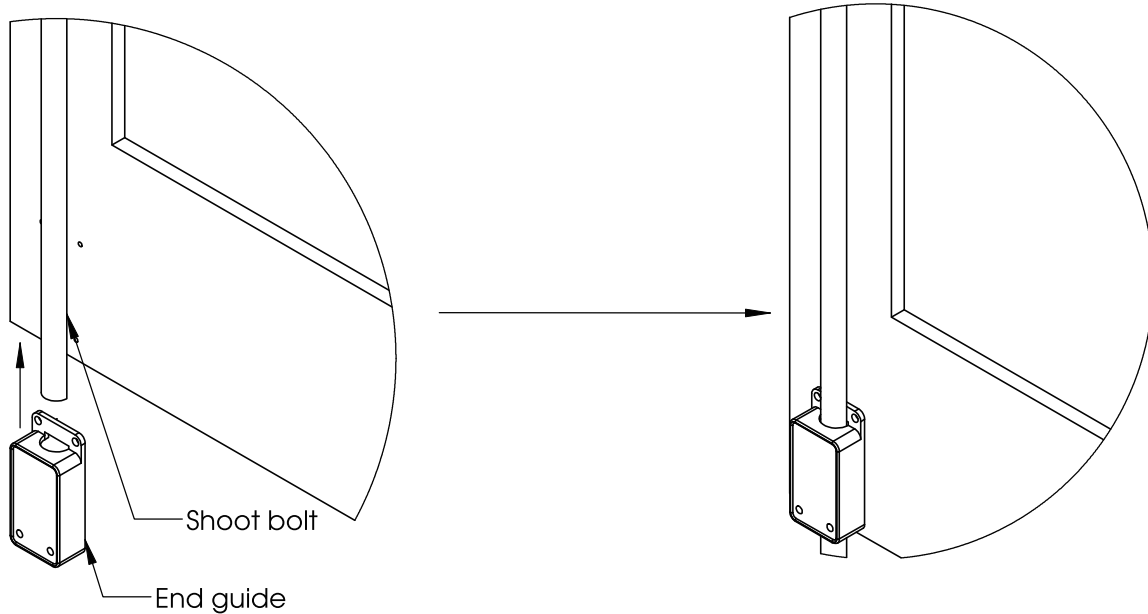

THE INFORMATION CONTAINED IN THIS DRAWING IS THE SOLE PROPERTY OF ERIC MORRIS & COMPANY. ANY REPRODUCTION IN PART OR AS A WHOLE WITHOUT THE WRITTEN PERMISSION OF ERIC MORRIS & COMPANY IS STRICTLY PROHIBITED.

TITLE:

DO NOT SCALE DRAWING

SCALE:1:1

SHEET 1 OF 1



Phone: +1-856-997-0222  
 Fax: +1-856-294-5116  
 Email: [info@ericmorrisandco.com](mailto:info@ericmorrisandco.com)  
 Web: <http://www.ericmorrisandco.com>  
 Address: ERIC MORRIS & COMPANY  
 7249-A Browning Road  
 Pennsauken, NJ 08109

15) Insert each of the shoulder screws back into the concealed guides as in steps 9 & 10. Swing bolts around and re-attach the bolts to the attachment bars after applying a small amount of Loctite to the # 10 screws.

16) Remove the four (4) #8 screws holding the cremone case in place. Place a frog over each end of the cremone case making sure to align the holes in the frog with the holes in the case and the pre-drilled holes in the door (as shown below).

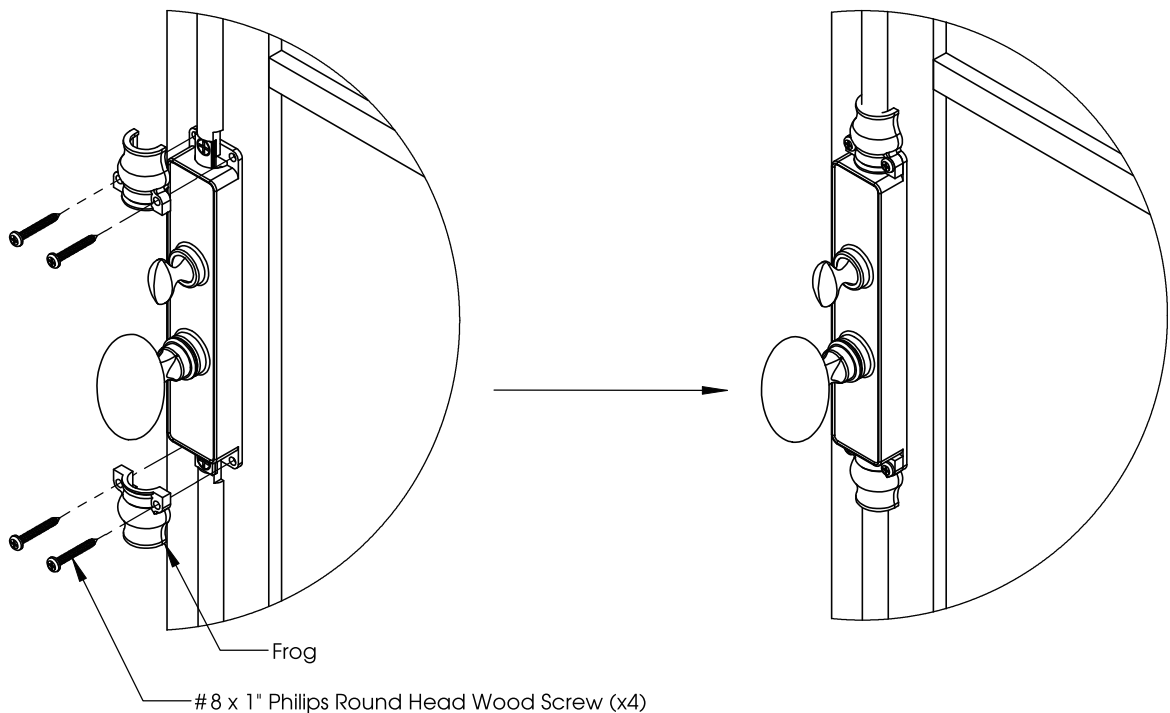

17) Re-install the four (4) # 8 screws and tighten until secure.

18) Slide each of the end guides into place over the pre-drilled holes in the door. Place a frog over each flange as shown below. Insert a #8 x 1" Phillips Wood screw into each screw hole and tighten until secure.

19) Finally, insert a #8 x 1 1/2" Philip round head wood screw through each of the screw holes in the end guides and tighten until secure.

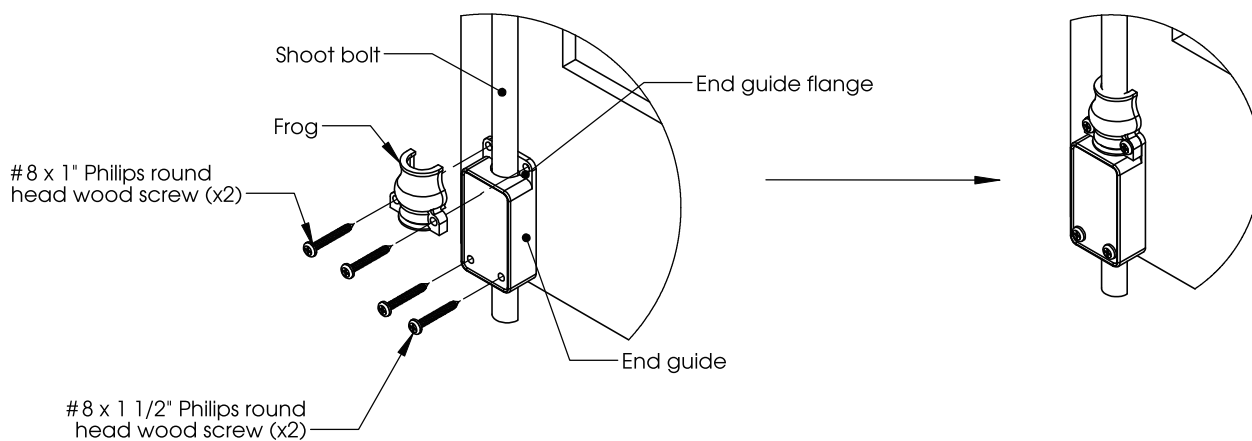

THE INFORMATION CONTAINED IN THIS DRAWING IS THE SOLE PROPERTY OF ERIC MORRIS & COMPANY. ANY REPRODUCTION IN PART OR AS A WHOLE WITHOUT THE WRITTEN PERMISSION OF ERIC MORRIS & COMPANY IS STRICTLY PROHIBITED.

TITLE:

DO NOT SCALE DRAWING

SCALE:1:1

SHEET 1 OF 1



Phone: +1-856-997-0222  
 Fax: +1-856-294-5116  
 Email: [info@ericmorrisandco.com](mailto:info@ericmorrisandco.com)  
 Web: <http://www.ericmorrisandco.com>  
 Address: ERIC MORRIS & COMPANY  
 7249-A Browning Road  
 Pennsauken, NJ 08109