

Phillips Screwdriver

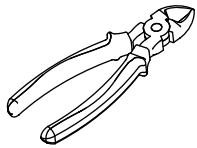

Diagonal/Cutting Pliers

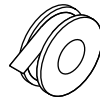

Sealant Tape



Soldering Torch

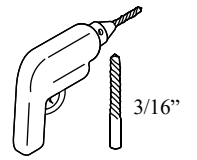

Drill with 3/16" Bit

For F1002B:

CxC Connection

After removing the plastic mud guard, two integral stops and cartridge with raised block, solder 1/2" copper tube to valve inlet and outlet ports. Avoid soldering excessively at high temperature.

IPS Connection:

Apply teflon tape or other thread sealant onto male inlet and outlet ports, and connect water supplies.

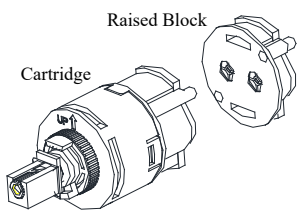

For F1002B-PEX:

Use PEX connections with ASTM F1807 compliant copper crimp rings and ASTM F887 compliant PEX tubing.

For F1002B-PEX-W:

Use PEX connections with ASTM F1960 compliant cold expansion retaining rings and ASTM F887 compliant PEX tubing.

1. Turn off the water supply. Lay out the system. Determine pipe lengths. NOTE: Measurements shown in diagram are for reference only.

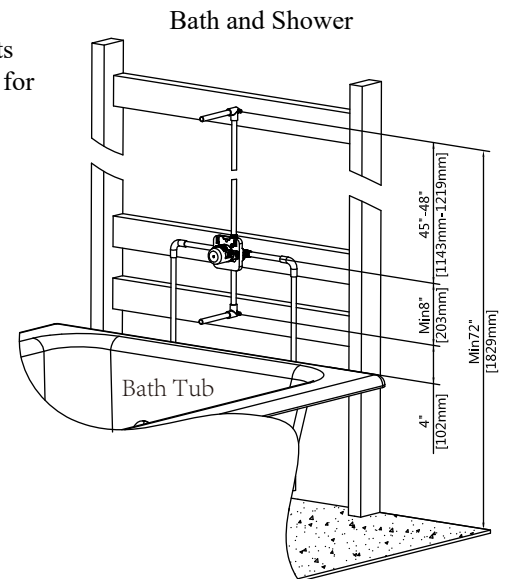

2. Install the outlet and inlet pipes to the valve body.

NOTE: Use only 1/2" (5/8"OD) copper pipe (type L or M) between the valve and bath spout for maximum flow.

IMPORTANT: Remove the cartridge, raised block and both integral stops prior to soldering. Avoid excessive heat.

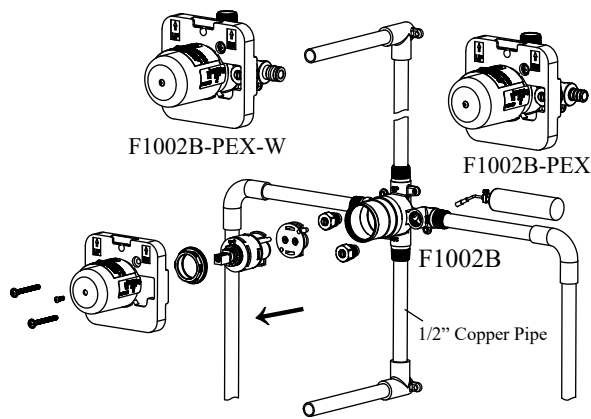

3. Configure back-to-back installations as shown.

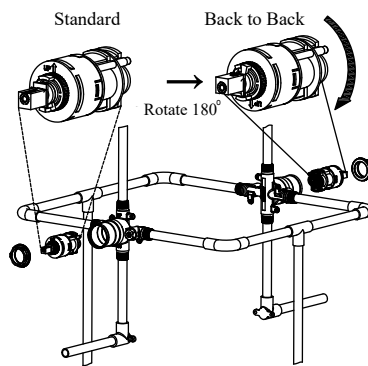

4. Re-assemble all components and re-attach the mud guard if required.

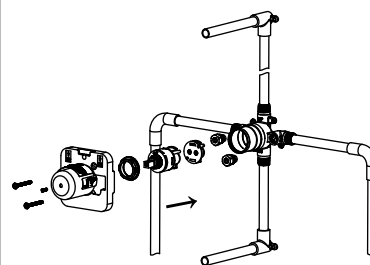

5. For installation onto a thick wall: Mount the valve body so that the front of the finished wall lies between the Min and Max indicated on the depth table.

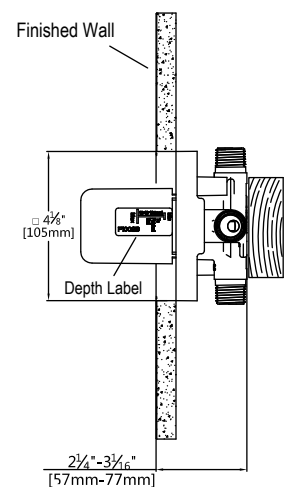

6. Mount the valve body onto the studs using supplied screws and bubble level to ensure a level/square installation.

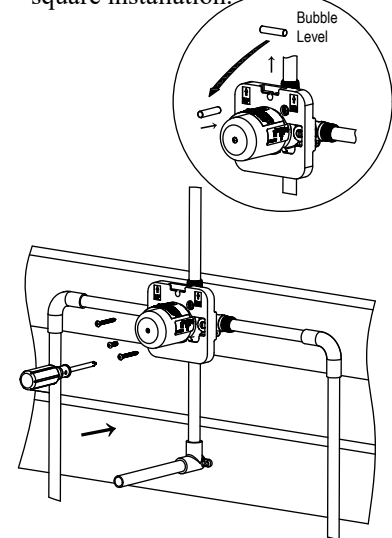

7. Turn on both cold and hot water supplies.

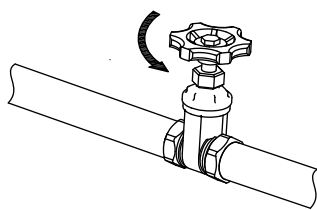

8. Remove the center screw using a Phillips screwdriver. Remove the plastic mud guard using diagonal/cutting pliers.

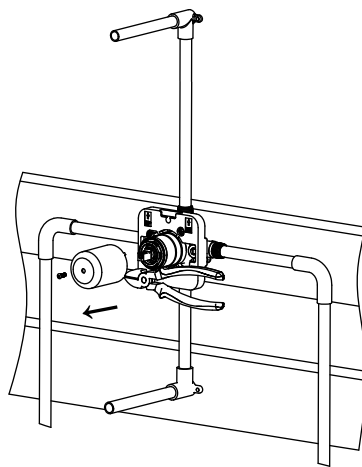

9. Install and rotate the handle to flush the pipe. Turn off the water and install the caps (not supplied). Turn the water back on and check for leaks.

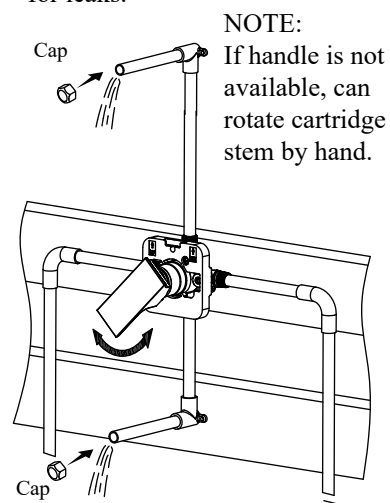

10. Turn the water supply off.

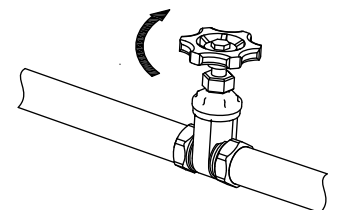

11. Replace the mud guard cone cover and tighten the center screw. Using the square edge of the mud guard as a template, cut a hole in the finished wall.

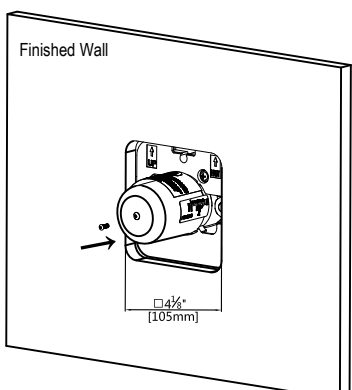

12. Remove the mud guard cone cover and install valve trims. (Trims are sold and packaged separately.)

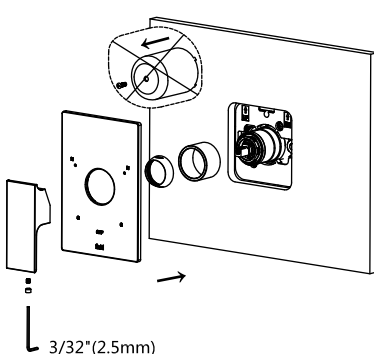

13. For Installation onto a Thin Wall Use the supplied cut out template to cut a hole in the finished wall. Test system as shown in #7-10 above.

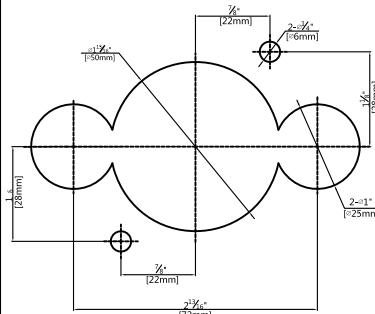

14. Remove 3 screws and cone cover from mud guard using diagonal/cutting pliers

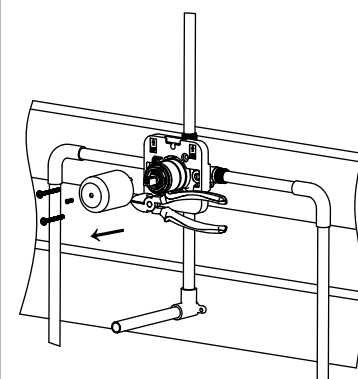

15. Secure the valve onto the thin wall using the two supplied panhead screws.

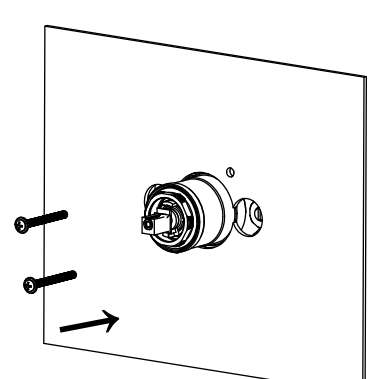

16. Both integral stops should be fully open while the valve is in use. Both integral stops should be fully closed while the valve is being serviced or under repair.

Turn clockwise to close intergral stop.

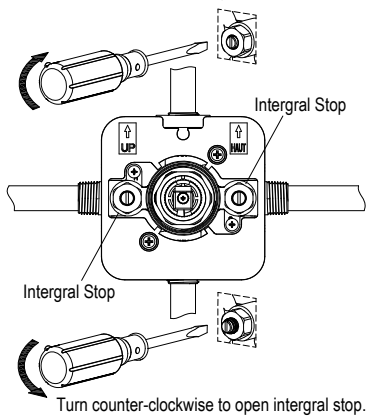

17. Deep Wall Installation:
If the valve body is installed too deeply behind the finished wall making installation of the cover plate and handle impossible, Extension Kit F-EXT1002 is available for purchase from fluid.
F-EXT1002 includes an extra long sleeve tube and a raised block.

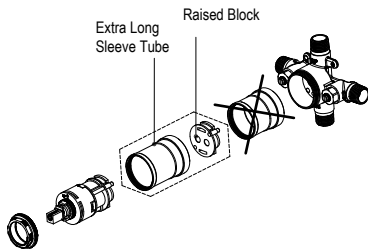

Operation Instructions:

When the handle points straight down, the valve is in the OFF position. Turning the handle left will direct water to one port and turning it right will direct water to the second port. Temperature is controlled by how far the handle is turned. The further the handle is turned left or right, the hotter the water will be to the corresponding port.

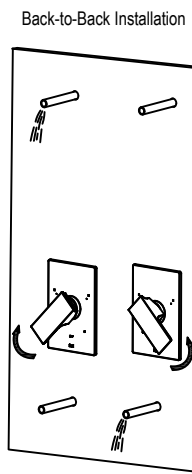
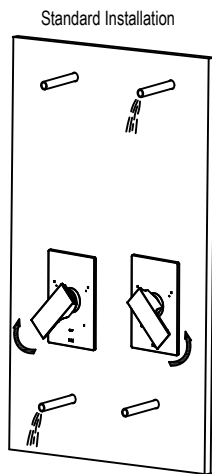

F1002B
F1002B-PEX
F1002B-PEX-W

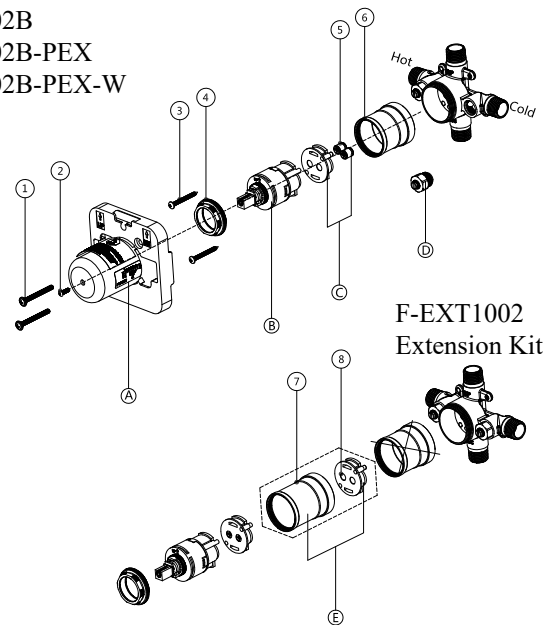

	ITEM#	DESCRIPTION
1	000.004.03.21.00	M5 x 45 Panhead Screw
2	000.004.03.02.00	M4 x 12 Screw
3	000.009.04.02.00	ST4.2 x 40 Screw
4	000.031.01.02.96	Retaining Nut
5	11.000.015.02.00	Check Valve
6	000.313.01.24.96	Sleeve Tube
7	000.313.01.32.96	Extra Long Sleeve Tube
8	000.042.12.05.00	Raised Block
A	000.315.12.10.45	Mud Guard
B	JL02BD	Pressure Balancing Cartridge
C	JL02BD-HJ11LA02	Raised Block w/ Check Valve
D	11.000.518.05.00	Integral Stop
E	F-EXT1002	Extension Kit

Need Help?

For additional assistance
Toll Free: 1 800 460 7019
help@sustainablesolutions.com
www.sustainablesolutions.com

fluid | Sustainable Solutions

