

Read and follow all instructions prior to installing your Aquatic fixture. Save these instructions for future reference. Failure to comply with these instructions may invalidate your warranty. For questions concerning installation and maintenance of your Aquatic shower or tub/shower, contact Technical Services at 800-945-2726.

Items Included

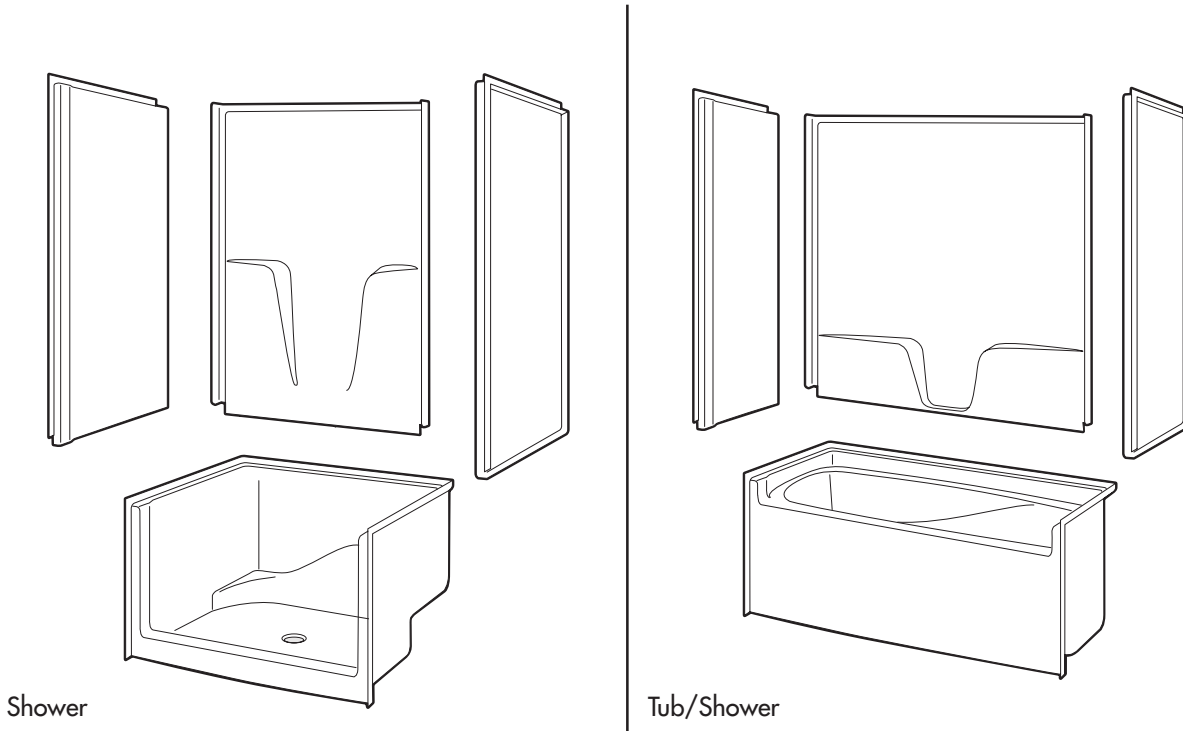

Tools Needed

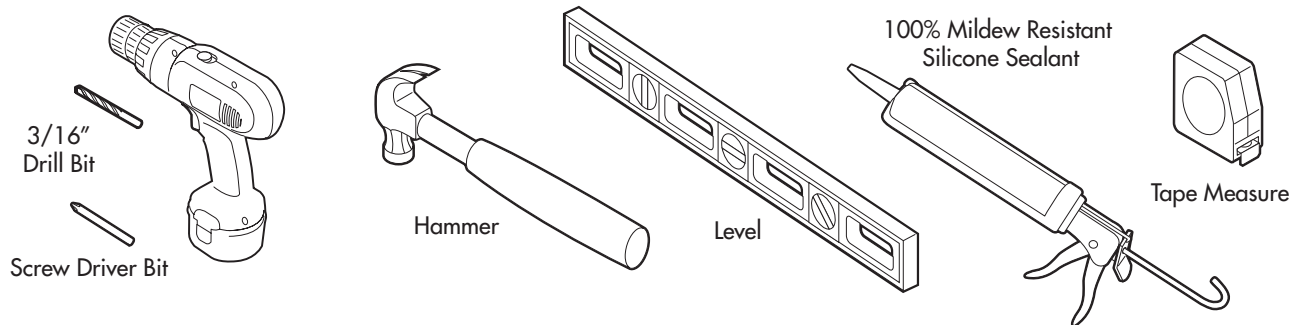



NOTICE: Please inspect the unit thoroughly before installation to make sure it has not been damaged during transportation. Under no circumstances should a damaged unit be installed. Neither Aquatic nor the distributor will be responsible for removal or reinstatement costs should a replacement be necessary due to installation of a damaged unit.

PRE-INSTALLATION PLANNING

1. Review job print and Aquatic rough-in dimensions; verify all key dimensions against actual job conditions.
2. Make sure framed-in alcove is of proper size, square and plumb; check floor for level.
3. If fire-rated alcove is required, approved finish material must be in place prior to unit installation to meet fire safety requirements of local building code and/or FHA/HUD Minimum Property Standards.
NOTE: Finished alcove must have interior dimensions shown on rough-in diagram to permit installation of unit.
4. No foundation materials are required on Aquatic Showers and Tub/Shower units.
5. Shower stalls require a 6" (150mm) diameter floor opening for 2" (50mm) IPS drain fitting connection. (See Diagram 1A)
6. Tub/Shower require a 6" x 12" (150mm x 305mm) floor opening for the 1 1/2" (40mm) drain, waste and overflow (DWO) kit. (See Diagram 1B)
7. Make sure all plumbing is complete and to code.
8. To avoid obstruction, make sure that supply lines and valve plumbing do not project into alcove during the installation process. Also, drain pipe must not project above floor level prior to installation.
9. On inside of plumbing wet wall of unit, note location of supply elbow and mixer valve. (see "Tubs and Shower Mounted Fittings" below)
10. To prevent scuffing while installing unit, cover the floor of the unit with a piece of cardboard or other protective material.
11. Fasteners for:
 - Wood framing - 1 1/2" galvanized roofing nails or #10 x 1 1/2" self-tapping washer head screws.
 - Concrete or block walls - 1" concrete nails and nailing tool.
 - Steel studs (18 ga.) - drill flanges and studs with 5/32" carbide bit and use #12 x 1" sheet metal screws.

Tub and Shower Mounted Fittings:

If mounting fittings on tub or shower, from stable reference points (back wall studs, floor), measure the locations of spout and valves. Note measurements:

Tub Filler: _____ Valve: _____

Shower Arm: _____ Valve: _____

(Mark dimensions only if shower arm is plumbed within bath fixture wall area.)

1A

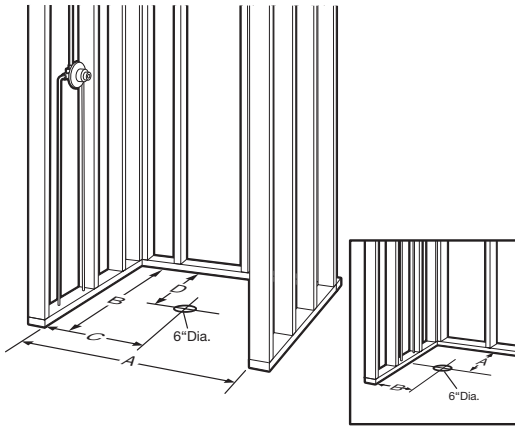

1B

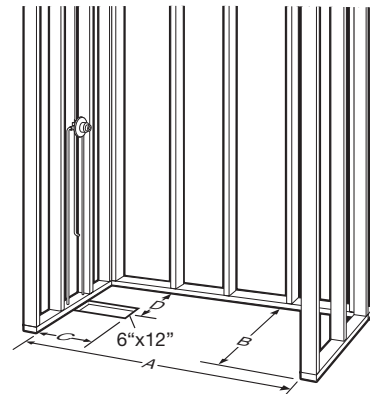

Check dimensions. For showers, refer to Diagram 1A; for tub-showers, refer to Diagram 1B.

2

Pre-install unit to ensure alcove is plumb, square and a level installation can be achieved (see steps 3 through 6).

3

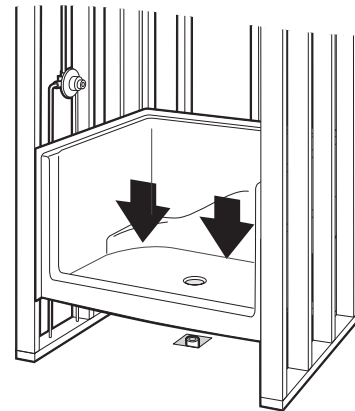

Lift and place base into framing.

4

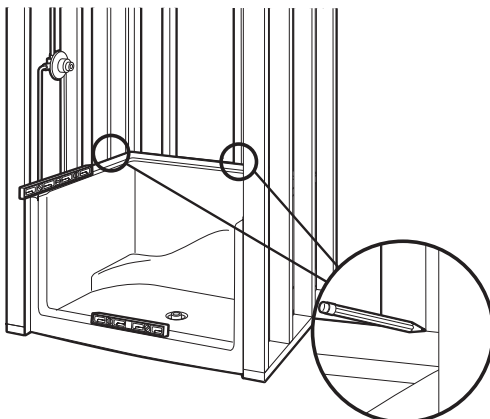

Level and mark all sides.

5

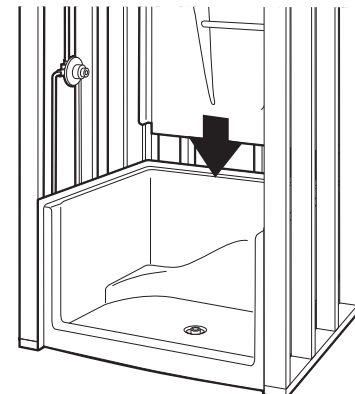

Lift and place back wall.

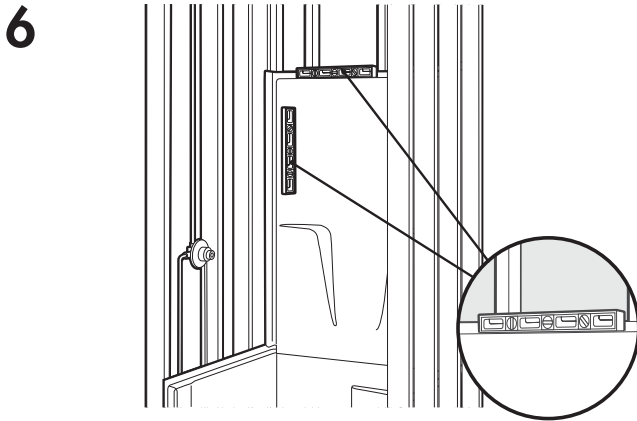

Level back wall vertically & horizontally. Shim if necessary.

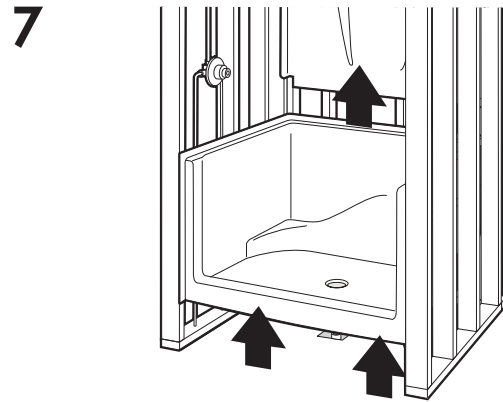

Remove back wall and base.

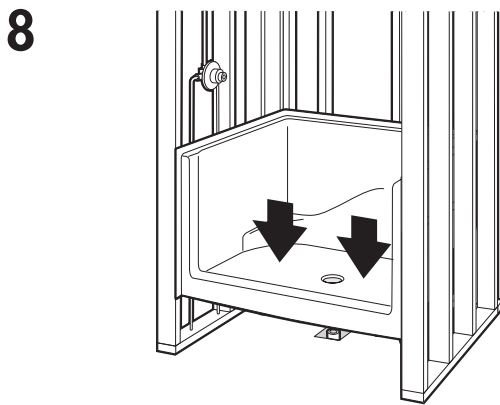

Install drain assembly per manufacturer's instructions. Place base into framing pocket.

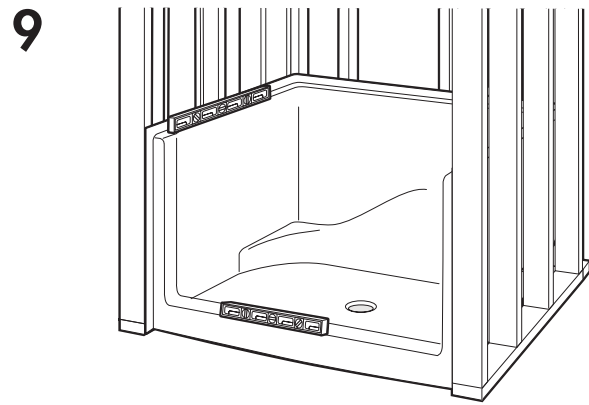

Tap down until level. Level lengthwise and widthwise using 3 ft. (915mm) level by shimming, if necessary. The unit should be set level.

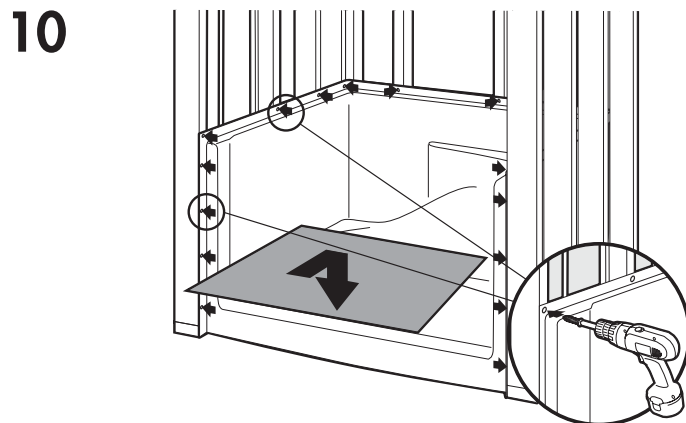

Pre-drill horizontal nailing flanges along top of base section and fasten into each corresponding stud. Pre-drill both (vertical) side nailing flanges and fasten to side studs 8" (200mm) on center. Place cardboard.

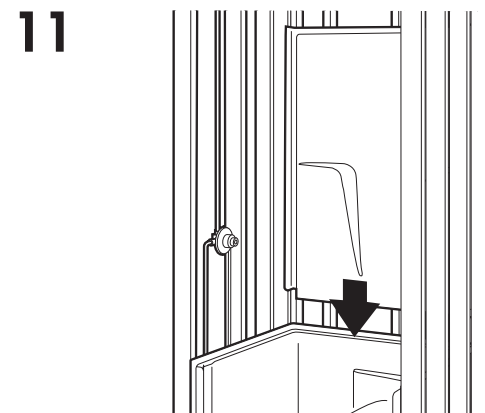

Lift and place back wall.

12

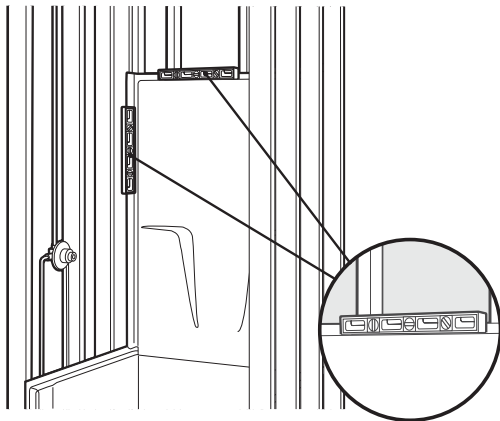

Level back wall vertically & horizontally.
Shim if necessary.

13

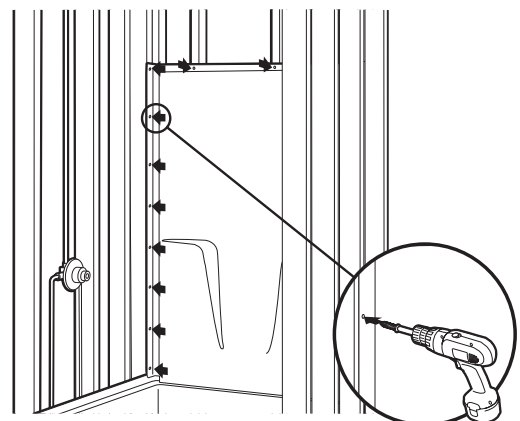

Pre-drill and fasten back wall. Pre-drill horizontal nailing flanges along top of back wall and fasten into each corresponding stud. Pre-drill both (vertical) side nailing flanges and fasten to side studs 8" (200mm) on center.

14

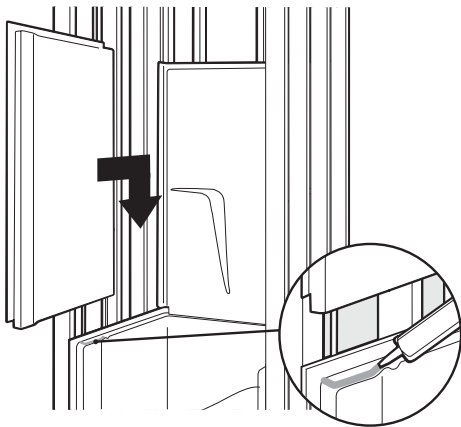

Silicone front edge, approximately 4" (100mm) from the front of the unit.

15

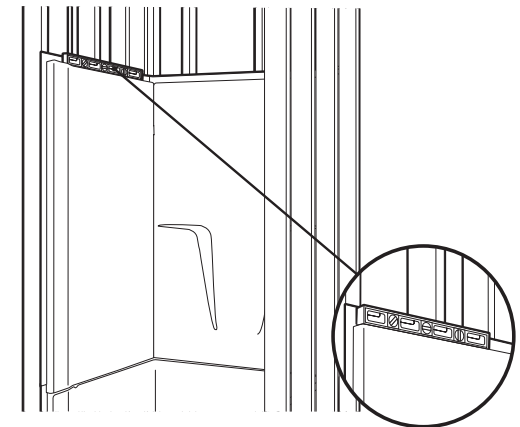

Slide left side wall into position. Check for level.

16

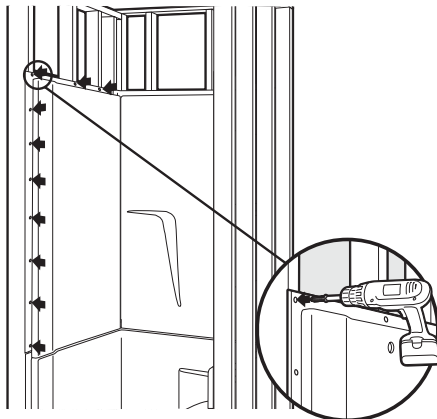

Pre-drill and fasten left wall. Pre-drill horizontal nailing flanges along top of left side wall and fasten into each corresponding stud. Pre-drill side (vertical) nailing flange and fasten to side studs 8" (200mm) on center.

17

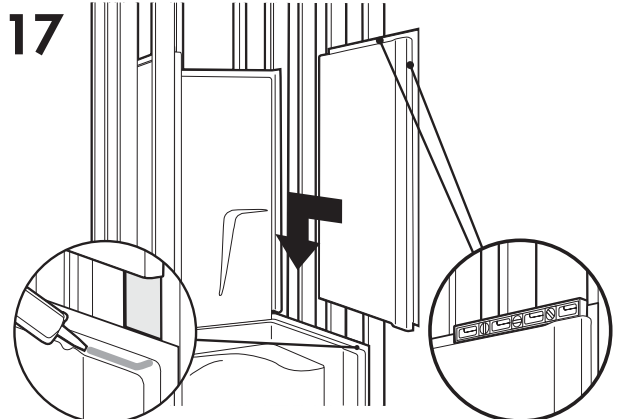

Silicone front edge, located approximately 4" (100mm) from the front of the unit.

18

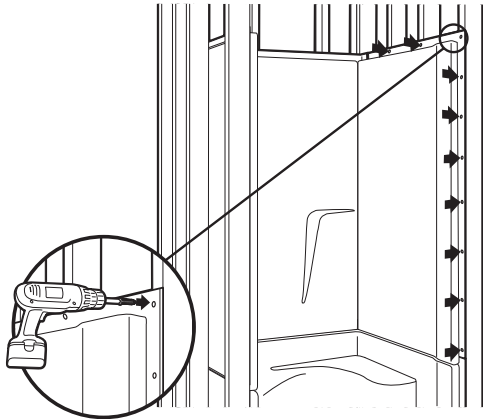

Pre-drill and fasten right wall. Pre-drill horizontal nailing flanges along top of right side wall and fasten into each corresponding stud. Pre-drill side (vertical) nailing flange and fasten to side studs 8" (200mm) on center.

19

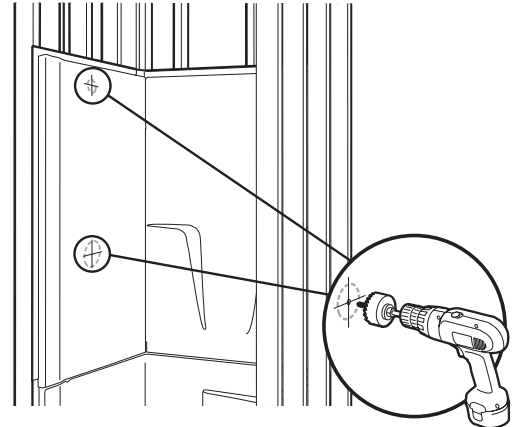

Refer to "Tub and Shower Mounted Fitting" for measurements. Using a hole saw (fine tooth or abrasive grit cutting edge), make necessary openings for filler and valves, drilling from inside (smooth side) out.

20

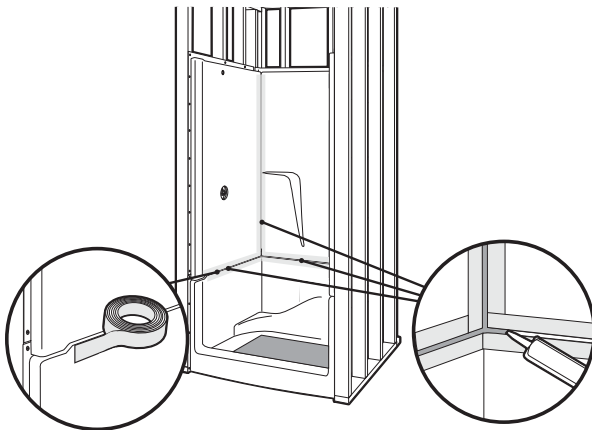

Clean unit. Apply a strip of painter's masking tape along the inside edge of each side of the seam where silicone sealant will be applied. Apply silicone to the joints/seams and smooth over with finger or caulking tool. While the silicone is still wet, remove tape strips along joint edges. NOTE: Allow silicone to cure for 24 hours (normal cure time) before using bath or shower. Humidity affects the curing process and different geographical areas experience varying degrees of humidity. Refer to silicone manufacturer's instructions for additional information related to curing times.

CLEAN-UP

CAUTION: DO NOT USE heat or solvent based cleaning fluids. **NOTE:** Do not remove warranty/maintenance adhered label. Warranty/User maintenance label must be left for occupant (Required by ANSIZ124).

1. Prevent staining. Remove all debris before plumbing leak test. Drain and wipe clean immediately after the inspection process. Use sponge with warm water and liquid detergent. Rinse, drain and wipe clean. Do not use abrasive cleansers such as scouring powders, steel wool, metal scrapers, sandpaper or anything else that might mar, dull or scratch the finish. Roofing tar or paints may be removed with rubbing alcohol or paint thinner (not lacquer thinner).
2. Plaster and latex paint may be removed with warm water, liquid detergent and brittle brush or plastic scraper. Do not use metal scraper or utensil to remove plaster or paint from finish.
3. Dull areas and light scratches can be restored to high gloss with white or cream-colored automotive rubbing compound, followed by application of coat or good quality white automotive polish (or similar) and buff with a soft cloth. **DO NOT WAX** standing surfaces of the unit bottom (this includes textured, slip resistant standing surfaces), which could result in greater risk of slipping and personal injury.
4. Remove minor scratches with 600 grit wet/dry sandpaper, followed by step #3.
5. Major gouges require professional repair.
6. See user maintenance label for more details.

USER MAINTENANCE INSTRUCTIONS

IMPORTANT! Use only recommended cleaners and procedures described herein. Use of other materials and methods may damage your bath fixture and void the warranty.

1. For normal cleaning, never use abrasive cleaners such as scouring powders or pads, steel wool, scrapers, sandpaper or anything else that could scratch or dull the surface of your Aquatic unit. Instead, use warm water and liquid detergents or non-abrasive cleansers, especially those bathroom cleansers recommended for fiberglass.
2. To keep your Aquatic fixture sparkling clean, apply a coat of good quality automotive paste wax or polish and buff to a high shine with a soft cloth or towel. Repeat every six months for easier cleaning and long lasting protection. **DO NOT WAX** standing surfaces of the unit bottom (this includes textured, slip resistant standing surfaces), which could result in greater risk of slipping and personal injury.
3. To restore a scratched or dull unit, use an automotive polishing compound applied with a clean cotton rag. Rub scratches and dull areas vigorously. Wipe off residues. Follow with automotive wax treatment described above. **DO NOT WAX** standing surfaces of the unit bottom (this includes textured, slip resistant standing surfaces), which could result in greater risk of slipping and personal injury.
4. To remove adhesive, try 3-M® natural cleaner, De-Solv-It® or similar materials. If residues remain, saturate small white cotton rag with nail polish remover and rub vigorously until the adhesive dissolves and disappears. These solvents are highly flammable and must be used sparingly and with caution. Do not allow solvent to go down the drain. Make sure not to contact plastic drain grates or other synthetic materials.
5. Rubber mats: If you use rubber "anti-skid" mat, make sure to remove it from the unit after each use to avoid harm to the surface finish.
6. Hard Water: Water in certain regions, if not wiped up after bathing/showering, may cause fading of some bath fixture colors. This is a natural occurrence beyond Aquatic's control. (See Warranty)

CAUTION: When using any cleaning or polishing materials, make sure to read and follow all package instructions carefully. Wear rubber gloves at all times and avoid contact with eyes, skin, clothing, rugs and furnishings. Make sure all residues are rinsed off thoroughly.



Customer Service | Technical Services | Warranty Services

1521 No. Cooper, Ste. 500
Arlington, TX 76011
PH: 800-945-2726, 817-801-8300
FAX: 866-544-5353

LITID1177

Rev 04.04.18